

Remove the Right Side Panel and Top Cover

卸下右側板與上蓋 / Retirez le panneau latéral droit et le capot supérieur / Entfernen Sie die rechte Seitenwand und die obere Abdeckung / Retire el panel lateral derecho y la cubierta superior / 右側のサイドパネルとトップカバーを取り外します

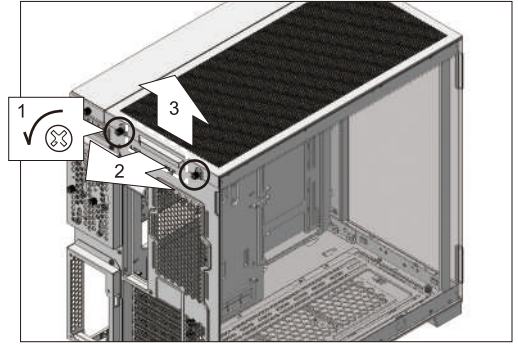
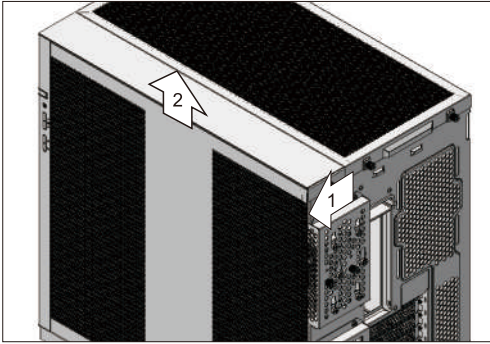

Remove the front & side glass panel

卸下前及側玻璃 / Retirez le panneau en verre avant et latéral / Entfernen Sie die vordere und seitliche Glasplatte / Retire el panel de vidrio frontal y lateral / 前面とサイドのガラスパネルを取り外してください

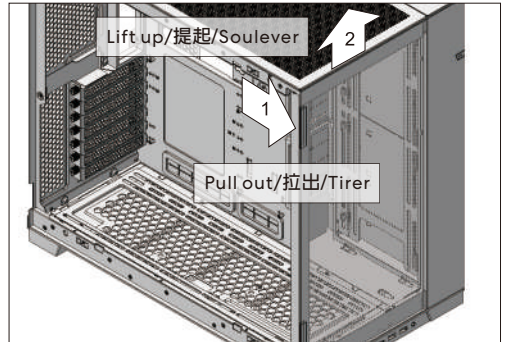
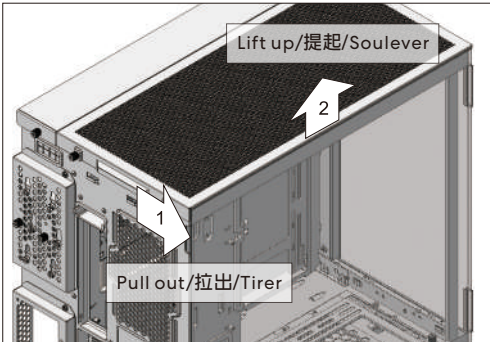

1. Remove the protecting clip / 移除保護膠條 / Retirez le clip de protection.
2. Peel off the protective film on both sides / 撕掉玻璃兩面的保護膜 / Décollez le film protecteur des deux côtés.
3. Recommend to keep the protecting clip on for transportation / 如需運送建議將保護膠條裝上 / Il est recommandé de conserver le clip de protection pour le transport.

Remove the Front Pillar

立柱卸除方式 /

Retirez le Pilier Avant /

Entfernen Sie die vordere Säule /

Quitar el Pilar Frontal /

フロントピラーを取り外す



Make sure to fix the pillar for transporting / 如需運送，務必將立柱鎖上 / Assurez-vous de fixer le pilier pour le transport

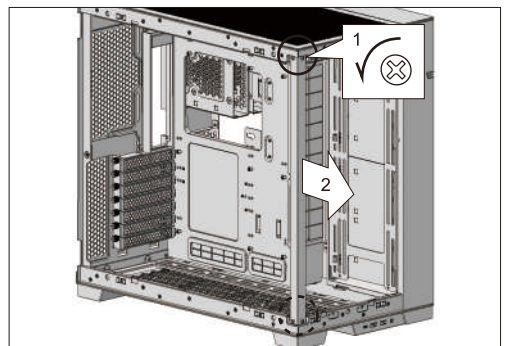

Normal

Normal Mode Specifications

正常模式規格 / Spécifications du mode normal / Spezifikationen für den Normalmodus / Especificaciones del modo normal / 通常モードの仕様



Refer to page 1-15, 28-29 to install this mode/要安裝此模式，請參閱第 1-15、28-29 頁/
Consultez les pages 1-15, 28-29 pour installer ce mode

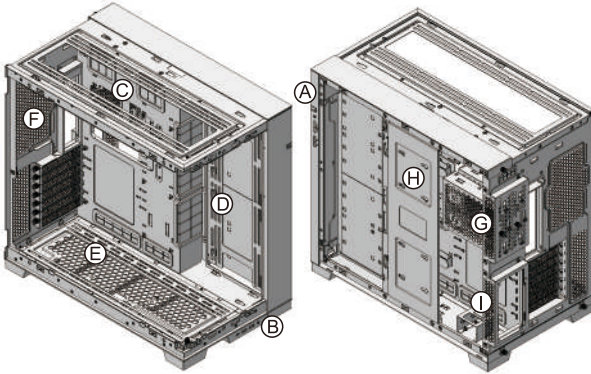

- (A) Power Button, Reset Button, C button for color control, M button for lighting mode control, B button for light brightness control
- (B) IO ports: 1 x AUDIO / Microphone Combo Jack, 2 x USB 3.0, 1 x USB 3.1 Type C,
- (C) Supporting 120 mm fan x 3 or 140 mm fan x 3 or 360 mm radiator x 1 or 420 radiator x 1
- (D) Supporting 120 mm fan x 3 or 140 mm fan x 3 or 360 mm radiator x 1 or 280 radiator x 1 **or 2.5" SSD x 4 or 3.5" HDD x 2**
- (E) Supporting 120 mm fan x 3 or 140 mm fan x 3 or 360 mm radiator x 1
- (F) Supporting 120 mm fan x 1
- (G) Removable HDD tray, Supporting 2.5" SSD x 2 or 3.5" HDD x 2
- (H) Removable HDD tray, Supporting 2.5" SSD x 2
- (I) Removable PSU mounting bracket

Reverse

Reverse Mode Specifications

倒置模式規格 / Spécifications du mode inversé / Spezifikationen für den Rückwärtsmodus / Especificaciones del modo inverso / リバースモード仕様



Refer to page 1-4, 16-29 to install this mode/要安裝此模式，請參閱第 1-4、16-29 頁/
Veuillez vous référer aux pages 1-4, 16-29 pour installer ce mode

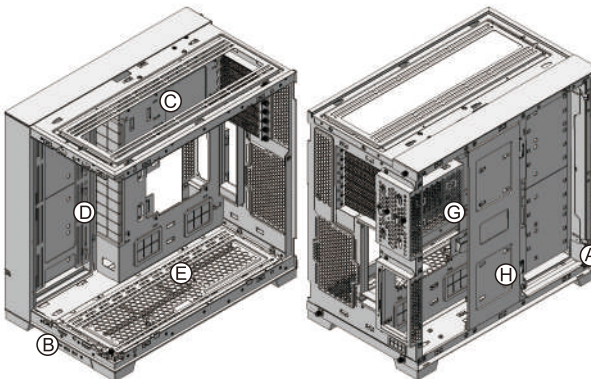

- (A) Power Button, Reset Button, C button for color control, M button for lighting mode control, B button for light brightness control
- (B) IO ports: 1 x AUDIO / Microphone Combo Jack, 2 x USB 3.0, 1 x USB 3.1 Type C
- (C) Supporting 120 mm fan x 3 or 140 mm fan x 3 or 360 mm radiator x 1, or 280 mm radiator x 1
- (D) Supporting 120 mm fan x 3 or 140 mm fan x 3 or 360 mm radiator x 1 or 280 radiator x 1 **or 2.5" SSD x 4 or 3.5" HDD x 2**
- (E) Supporting 120 mm fan x 3 or 140 mm fan x 3 or 360 mm radiator x 1
- (F) Supporting 120 mm fan x 1
- (G) Supporting 2.5" SSD x 1 + 3.5" HDD x 2 or 2.5" SSD x 2
- (H) Removable HDD tray, Supporting 2.5" SSD x 2
- (I) Removable PSU mounting bracket

Hardware List

零件部品一覧表 / Liste du matériel / Hardwareliste / Lista de hardware / ハードウェアリスト

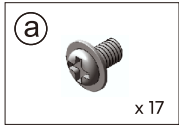

Screws
for motherboard/
2.5" SSD mounting

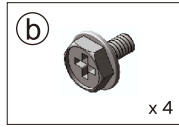

Screws
for PSU mounting

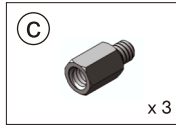

Stand-off bolt
(spare parts)
for M/B mount

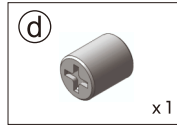

Tool
for stand-off bolt

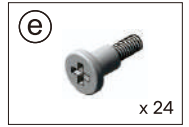

Screws
for 2.5" SSD mount

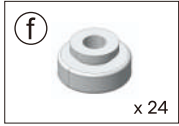

3.5" HDD mount
Anti-vibration rings
for 2.5" SSD



Screws
for 3.5" HDD mount

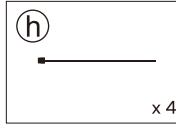

Cable ties
for cable
management

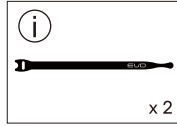

Velcro straps

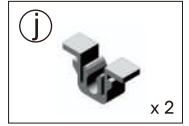

Female clips
(spare parts)
for side panel

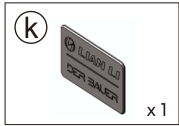

Name plate

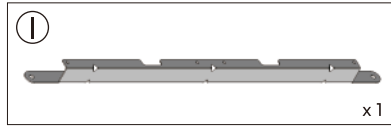

420 Radiator Mounting Bracket

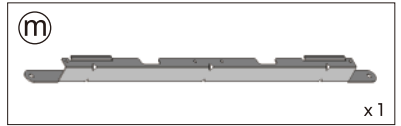

420 Radiator Mounting Bracket (with Hooks)



Screws
for 420 Radiator
Mounting Bracket

※ Exceeded quantity are spare parts.

※ 多餘の零件數量是備品。

※ Les pièces supplémentaires sont des pièces de rechange.

※ Zusätzliche Teile können als Ersatzteile verwendet werden.

※ Exceeded quantity are spare parts.

※ ネジには予備が含まれています。

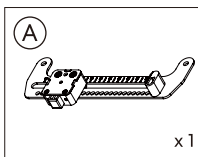

x 1

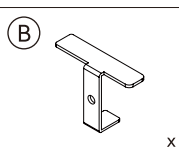

x 1

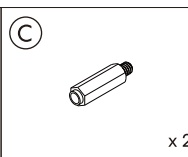

x 2

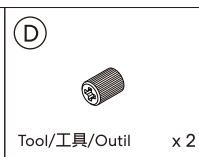

Tool/工具/Outil x 2

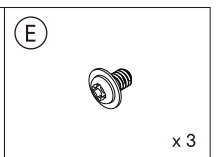

x 3

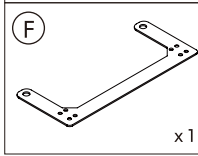

x 1

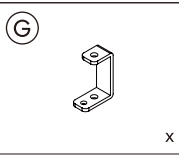

x 2

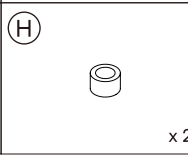

x 2

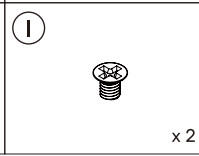

x 2

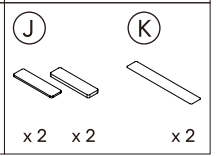

x 2

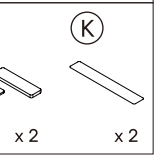

x 2

For graphic card anti-sag bracket kit installation/用於顯卡防下垂支架套件安裝/
Pour l'installation du kit de support anti-affaissement de la carte graphique

I/O Ports Function

I/O port 功能說明/
Installation du port I/O /
I/O-Port installieren /
Instalación de los puertos
de I/O /
I/Oポート機能

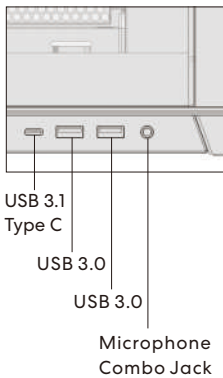
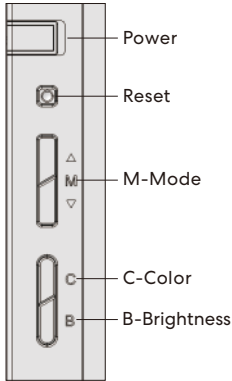

M-Mode/ M-模式/ M-Mode	Press one time / 按一次 / Appuyez une fois	14 Lighting Effects Mode Single-Color Modes: Breathing/Pulse/Interstellar Multi-Color Modes: Dual-Color Interstellar/Color Clash/ Color Paint/Meteor Stack/Ripple/Runway **Press "C" to change the color for above lighting effects mode Set Modes: Breathing Cycle/Rainbow/Rainbow Morph/ Color Spill / Fireworks *Above lighting effects can't change color 14種燈效 單色燈效: 呼吸 單色切換、脈動收縮、星際交鋒 多色燈效: 星際交鋒、雙色、撞色、來回擺盪、流星堆疊、 波光粼粼、跑馬燈 ** 以上按C可換顏色 一套配色: 呼吸 10色輪動、彩虹、漸變彩虹、文思泉湧、 煙火(不能切換顏色)/ 14 Modes d'Effets Lumineux Modes à Couleur Unie : Respiration/Impulsion/ Intergalactique Modes Multicolores : Intergalactique à Deux Couleurs/ Choc de Couleurs / Peinture de Couleurs / Empilement de Météores / Ondulation / Piste ** Appuyez sur "C" pour changer la couleur des modes d'effets lumineux ci-dessus Modes Définis : Cycle Respiratoire/Arc-en-Ciel/Morphing Arc-en-Ciel/Déversement de Couleurs/Feux d'Artifice * Les effets lumineux ci-dessus ne peuvent pas changer de couleur"
	Long press 3 sec/ 長按3秒/ Appuyez longuement 3 secondes	Sync or deactivate motherboard mode/ 同步或解除主板模式/ Synchroniser ou désactiver le mode de la carte mère
C-Color / C- 顏色 / C-Couleur	Press one time / 按一次 / Appuyez une fois	Single-color effects switch and pure color mode has 11 colors. Multi-color effects switch has 5 sets/ 切換單色燈效、純色模式共11色，切換多色燈效共5組/ Le commutateur d'effets monochromes et le mode couleur unie ont 11 couleurs. Le commutateur d'effets multicolores a 5 ensembles
	Long press 3 sec / 長按 3 秒 / Appuyez longuement 3 secondes	Enter or deactivate pure color mode with a total of 11 colors (Fixed colors: Red, Green, Blue, White, Orange, Yellow, Teal, Sky Blue, Light Blue, Purple, Magenta)/ 進入或解除純色模式共11色(定色: 紅色, 綠色, 藍色, 白色, 橘色, 黃色, 青綠色, 天藍色, 淺藍色, 紫色, 洋紅色)/ Activez ou désactivez le mode de couleur pure avec un total de 11 couleurs (Couleurs fixes : Rouge, Vert, Bleu, Blanc, Orange, Orange, Jaune, Vert d'eau, Bleu ciel, Bleu clair, Violet, Magenta)
B- Brightness/ 亮度/ Luminosité	Press one time / 按一次 / Appuyez une fois	Adjust the brightness of the lighting in five levels (100%, 75%, 50%, 25%, 0%)/ 調整燈光亮度，共五段(100%, 75%, 50%, 25%, 0%)/ Ajustez la luminosité de l'éclairage sur cinq niveaux (100 %, 75 %, 50 %, 25 %, 0 %)

Details for the lighting strips: 1.Both the top and bottom each have 47 ARGB LEDs. 2.Included memory function. 3.The default lighting effect mode is Fireworks/ARGB光效說明：一、支持ARGB燈數：上下各47顆。二、帶記憶功能(預設為煙火燈效)。

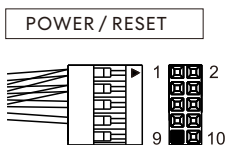

Definition	
1	Power LED+
3	Power LED-
5	Power SW+
7	Power SW-
6	Reset SW+
8	Reset SW-

USB 3.0 Supports motherboard
USB 3.0 20 Pin header

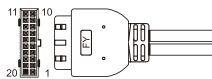

USB 3.1 GEN.2

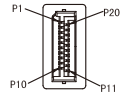

HD AUDIO

Blue 10 8 9 Green
Black purple 8 7 Key
Yellow 6 5 Orange
Gray 4 3 N.C.
Red 2 1 GND+H.S. TUBE



2.5" SSD Installation

2.5" SSD 安裝 / Installation de 2.5" SSD /

2.5" SSD-Installation / Instalación de 2.5" SSD /

2.5" SSD の取り付け

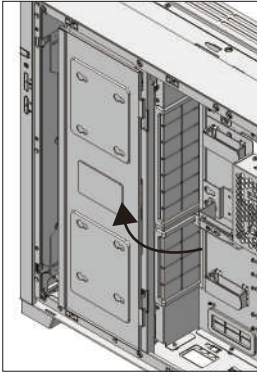

Way 1: Swing 180° to open/
使用方式一：翻轉180度/
Méthode 1: Pivotez à 180°
pour ouvrir

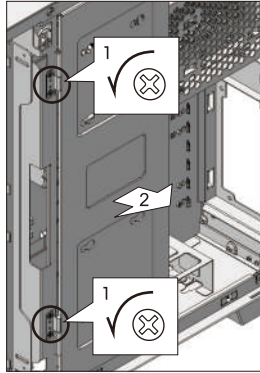

Way 2: Release/
使用方式二：取下/
Voie 2 : Libérer

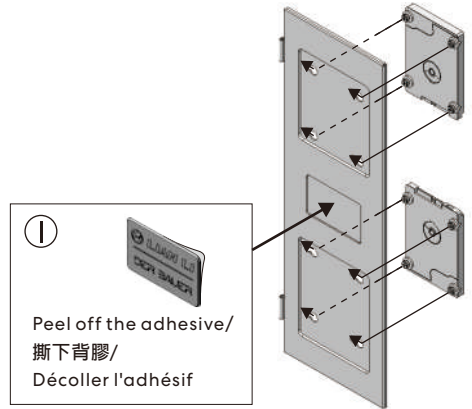
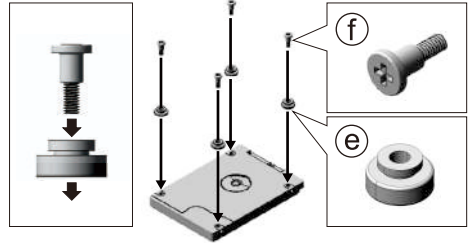

PSU Installation

電源供應器安裝 /

Installation du plateau de bloc d'alimentation /

PSU-Einsatz installieren /

Instalación de la fuente de alimentación /

電源のインストール

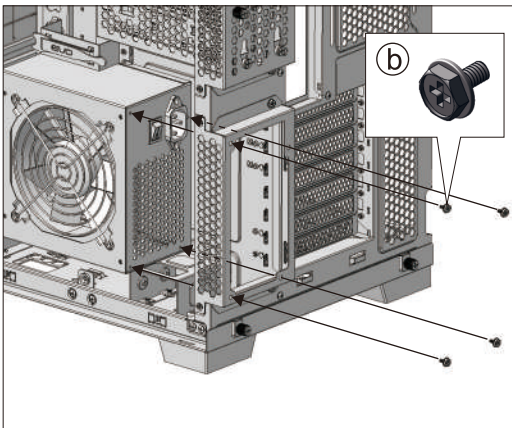

Way 1: Install Directly/使用方式一：直接安裝/
Méthode 1 : Installer directement

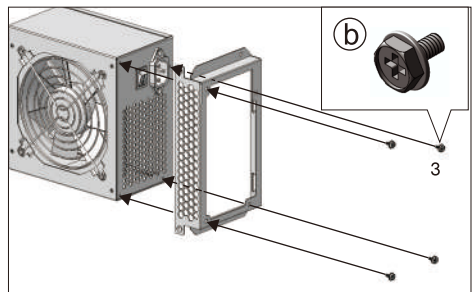
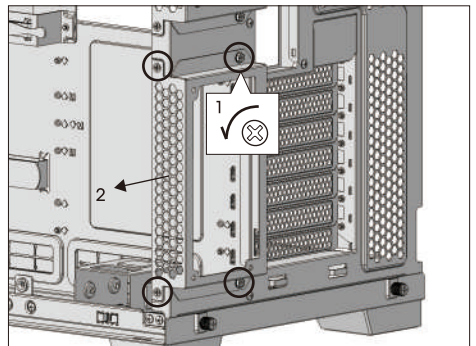

Way 2: Remove the bracket and install/使用方式二：
拆下支架安裝/Voie 2 : Retirez le support et installez

IO Module Location

I/O port 位置變換 / Changement de position du port d'E/S / Positionsänderung des I/O-Ports /
Cambio de posición del puerto de E/S / I/Oポートの位置変更

Location 1(Default mode)/位置 1(預設模式)/
Emplacement 1(mode par défaut)

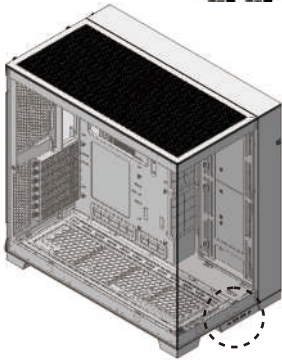
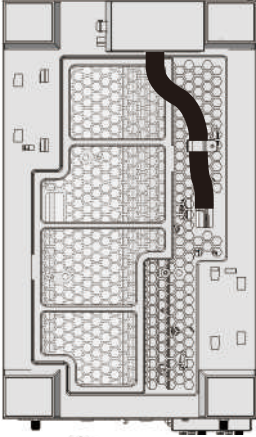

Location 2/位置 2/
Emplacement 2

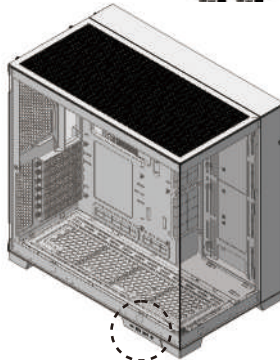
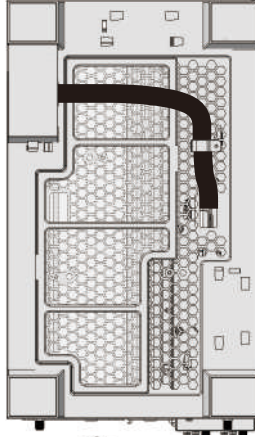

Location 3/位置 3/
Emplacement 3

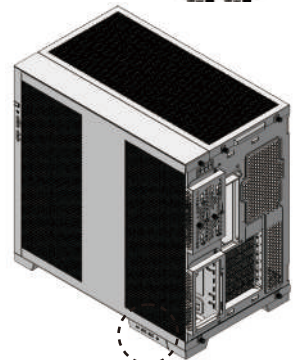
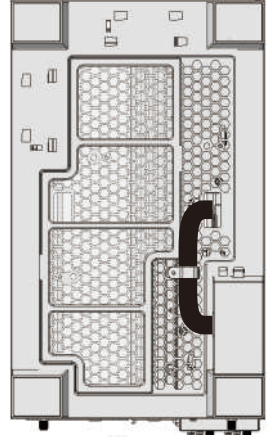

Remove the I/O module/
I/O port 卸除/
Retirer le module I/O

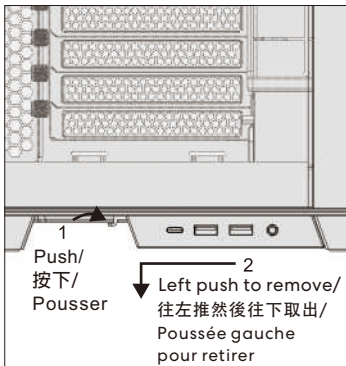

Remove the cable clip/
整線扣卸除/
Retirer le serre-câble

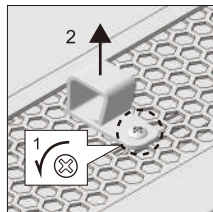

Install the cable clip/
整線扣安裝/
Installez le serre-câble

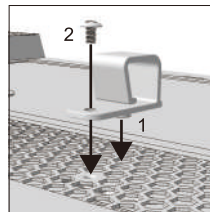

The possible position
for the cable clip/
整線扣變換位置示意/
Les positions possibles
pour le clip de câble

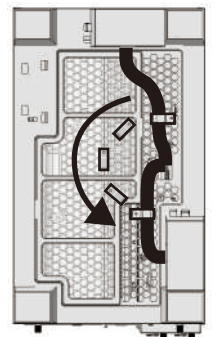

Motherboard Installation

主板安裝/Installation de la carte mère / Mainboard-Installation / Instalación de la placa base /
マザーボードの取り付け

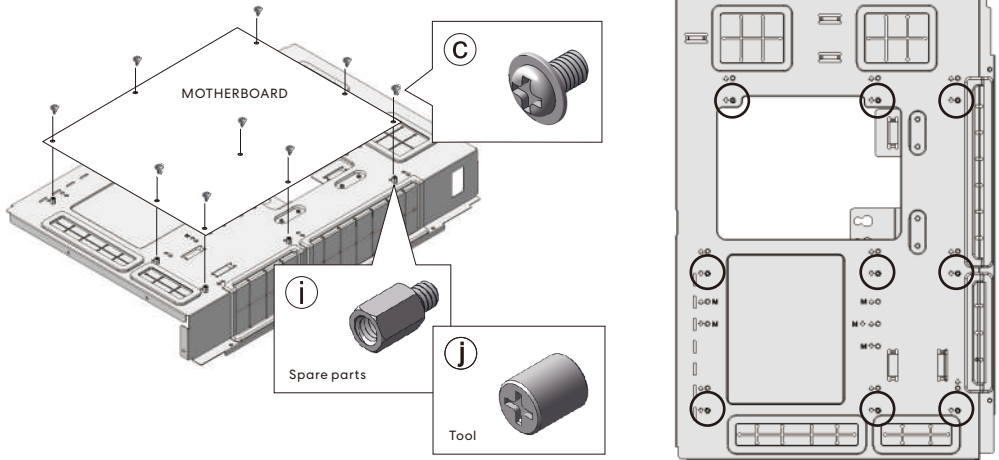

Support of Lower Position (Default Position)

下置模式支援説明(出廠預設)/Support de Position Inférieure (Position par Défaut)/Unterstützung der unteren Position
(Standardposition)/Soporte de Posición Inferior (Posición Predeterminada) /下部位置のサポート (デフォルトの位置)

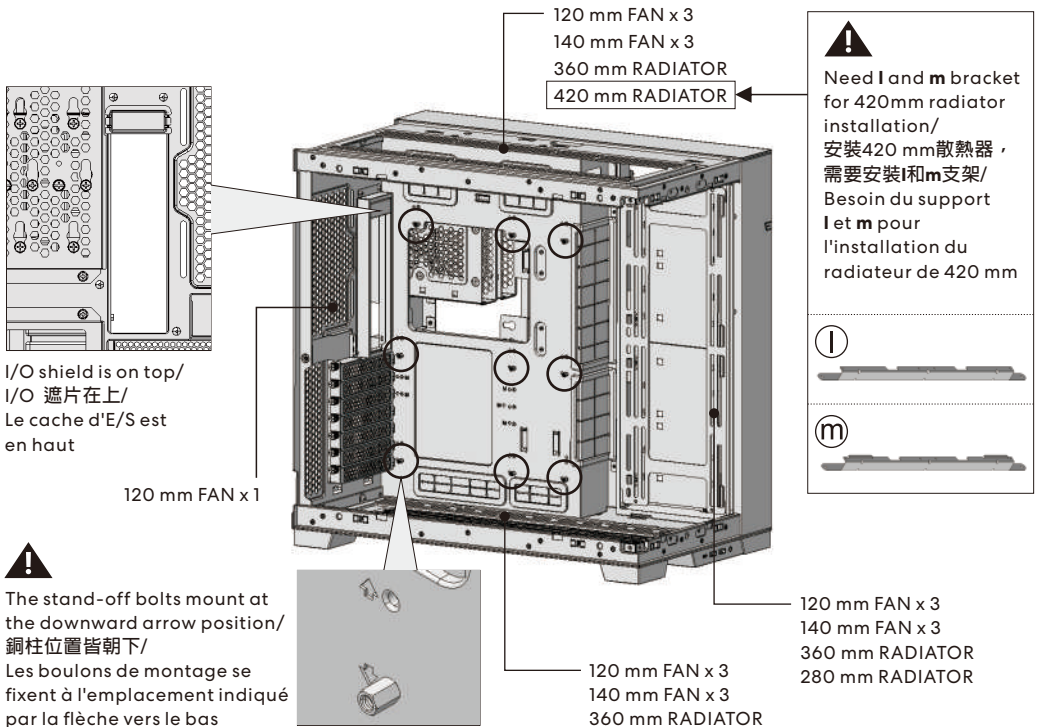

Switch Motherboard Mounting Position

模式變換說明/Changer la Position de Montage de la Carte Mère/Mainboard-Montageposition wechseln/
Cambiar la Posición de Montaje de la Placa Base/マザーボード取り付け位置の切り替え

Move the stand-off bolts position/
更換銅柱位置/Déplacer la position des entretoises à vis

Change the position of the I/O shield/更換I/O遮片位置/
Changer la position du cache d'E/S

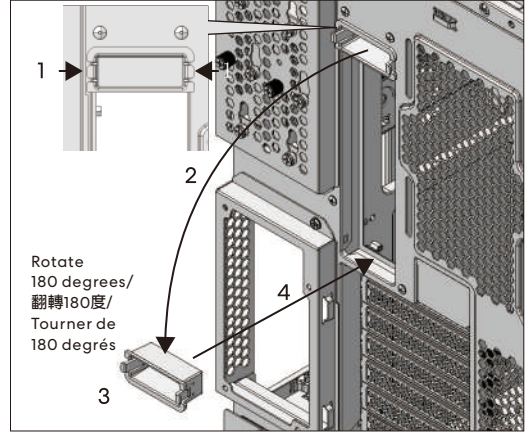
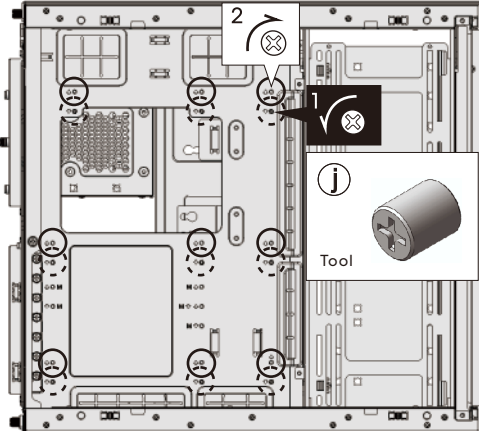

Support of Upper Position

上置模式支援說明/Support de Position Supérieure/Unterstützung der oberen Position/Soporte de Posición Superior/
上部位置のサポート

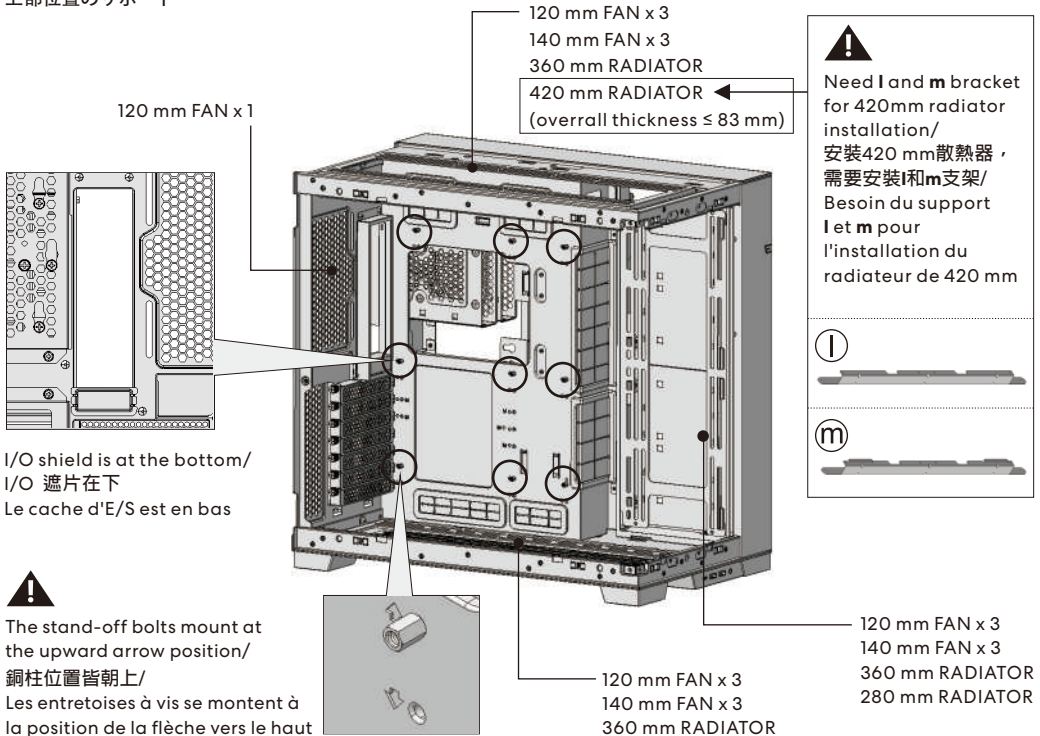

2.5" SSD, 3.5" HDD Installation

2.5" SSD, 3.5" HDD 安裝 / Installation de 2.5" SSD, 3.5" HDD / 2.5" SSD, 3.5" HDD-Installation /
Instalación de 2.5" SSD, 3.5" HDD / 2.5" SSD, 3.5" HDD の取り付け

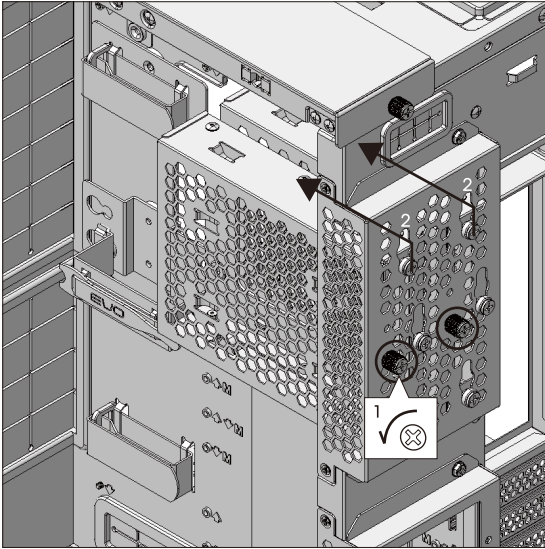

If space is needed, the hard drive cage can be removed/
如有空間需求可將硬碟籠卸除/
Si de l'espace est nécessaire, la cage du disque dur peut être retirée

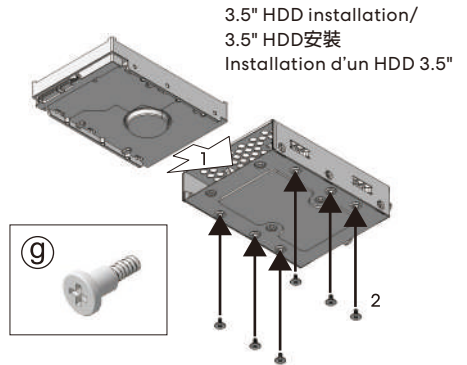
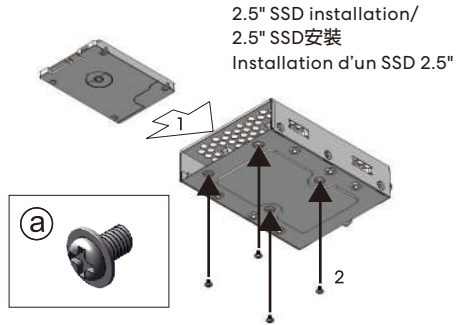

Remove the dust filters

灰塵濾網拆卸 / Retirer les filtres à poussière / Entfernen Sie die Staubfilter / Retire los filtros de polvo /
ダストフィルタを取り外す

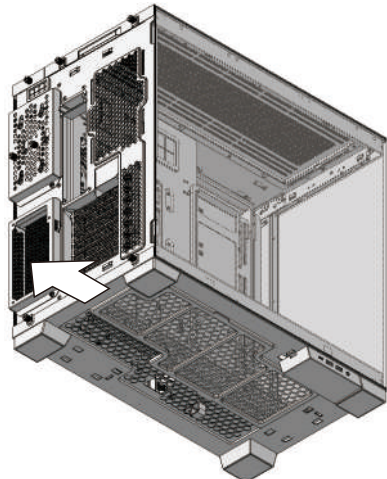
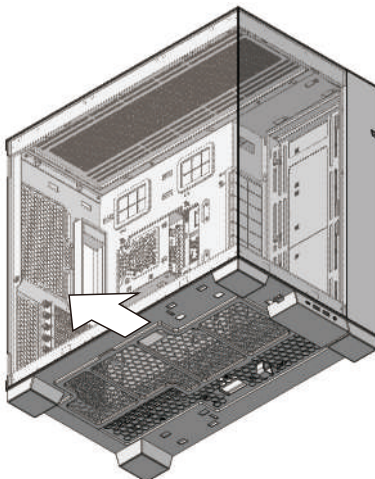

Cable management

線材整理 / Gestion des câbles / Kabelmanagement /
Mantenimiento de cable / ケーブル管理

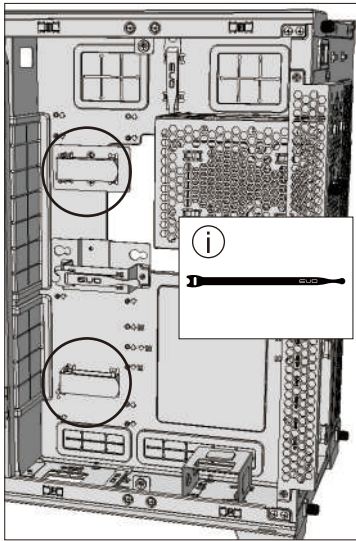

Cable holder installation

整線扣安裝方式 / Installation complète de la boucle du
câble / Installation der gesamten Kabelschnalle /
Instalación de hebilla de cable completo /
全ラインバックルの取り付け

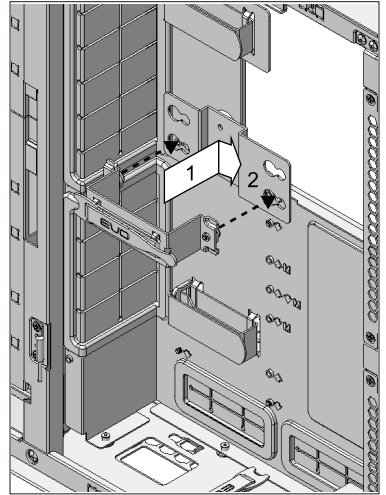
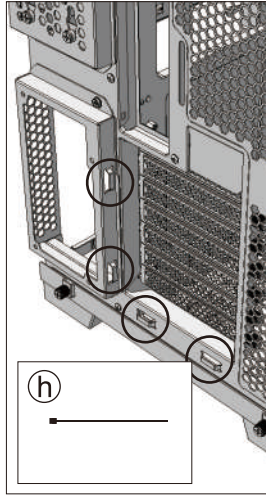

Use of cable holder

整線扣整線說明 / Description complète de la ligne complète de la boucle du câble / Ganze Beschreibung der
gesamten Kabelschnalle / Descripción de toda la línea de hebilla de cable completo / バックル全体 ライン全体

Keep the big cables in the cable
holders/

先將粗線整在金屬框架內/
Gardez les gros câbles dans les
porte-câbles

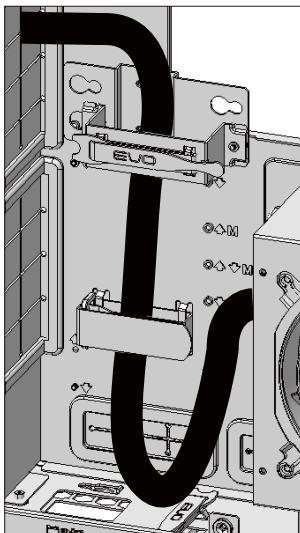

Hold the small cables with the
velcro straps/

再將細線使用魔鬼氈整好/
Maintenez les petits câbles avec
les bandes velcro

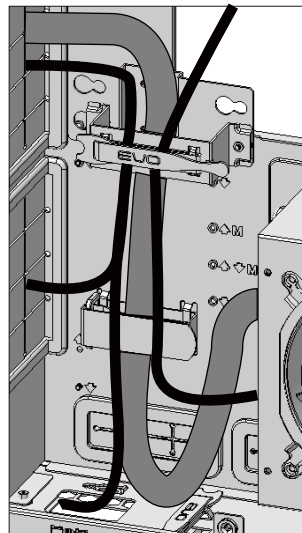

Remove the velcro strap to place
a controller/

亦可拆下魔鬼氈作為控制器黏貼處/
Retirez la bande velcro pour
placer un contrôleur

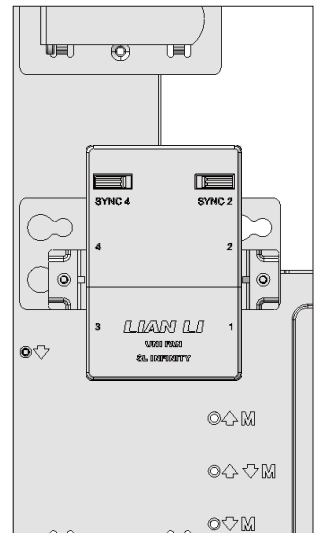

Remove the Bottom Fan Bracket

卸除下風扇支架 / Retirez le support inférieur du ventilateur / Entfernen Sie die untere Lüfterhalterung /
Retire el soporte del ventilador inferior / 下部ファンブラケットを取り外します

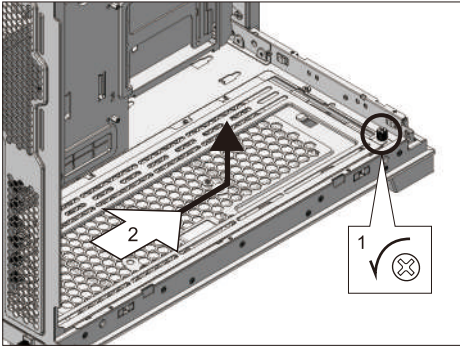

Hint to mount the fan brackets/

安裝扣位提示/

Indication pour monter les supports de ventilateur

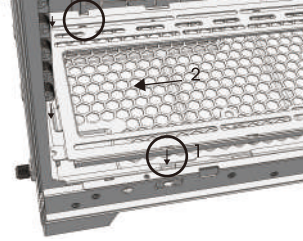

Remove the Top Fan Bracket

卸除上風扇支架 / Retirez le support du ventilateur supérieur / Entfernen Sie die obere Lüfterhalterung /
Retire el soporte del ventilador superior / 上部ファンブラケットを取り外します

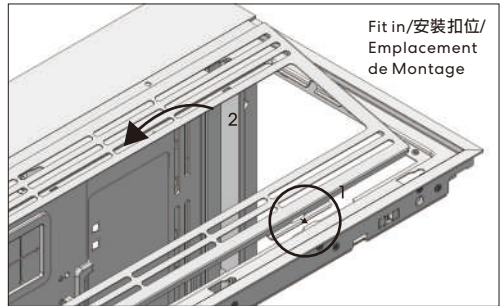
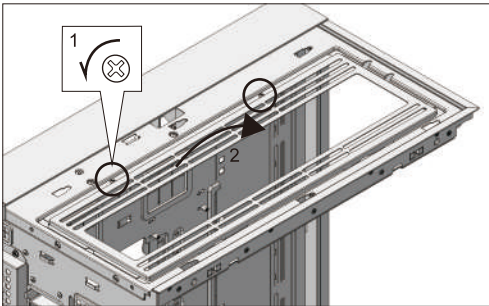

Instructions for Using the 420 Water Cooling Mounting Bracket/420水冷安裝架使用方式/
Instructions d'utilisation du support de montage pour le refroidissement à l'eau 420

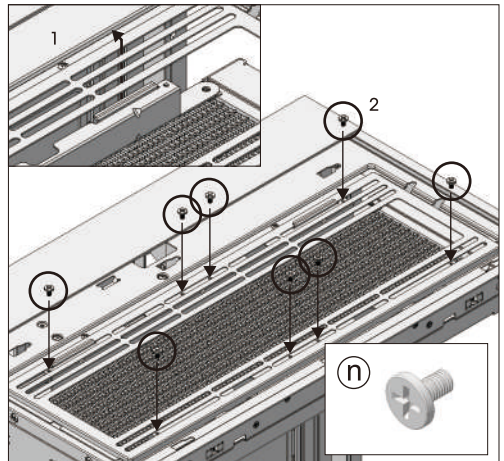
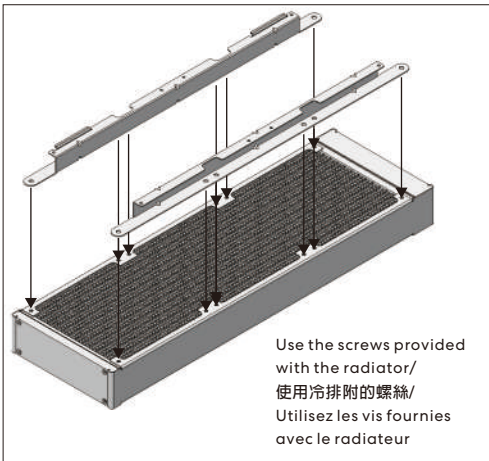

Remove Hard Drive Bracket

卸除硬碟安裝架 / Retirer le support de disque dur / Festplattenhalterung entfernen / Quitar el soporte del disco duro / ハードドライブブラケットを取り外す

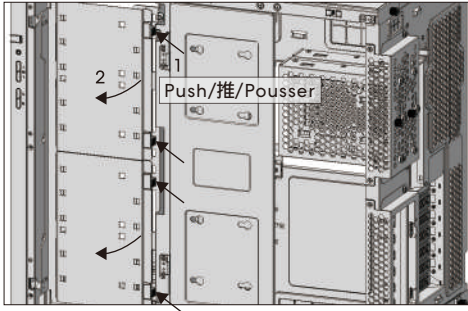

Fit in / 安裝扣位 /
Emplacement de Montage

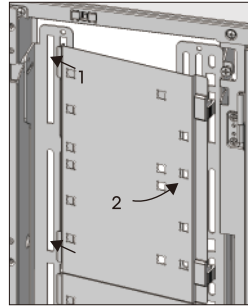

Crossover Space / 過線空間 /
Espace de Croisement

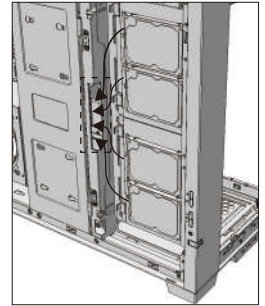

2.5" SSD, 3.5" HDD installation

2.5" SSD, 3.5" HDD 安裝 / Installation de 2.5" SSD, 3.5" HDD / 2.5" SSD, 3.5" HDD-Installation / Instalación de 2.5" SSD, 3.5" HDD / 2.5" SSD, 3.5" HDD の取り付け

2.5" SSD installation/
2.5" SSD 安裝
Installation d'un SSD 2.5"

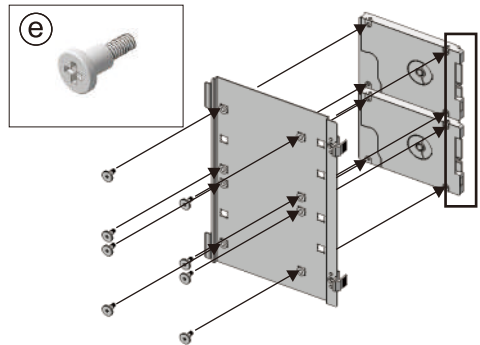
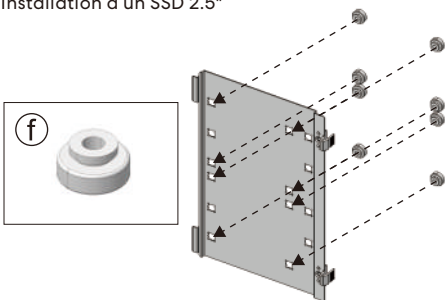

3.5" HDD installation/
3.5" HDD 安裝
Installation d'un HDD 3.5"

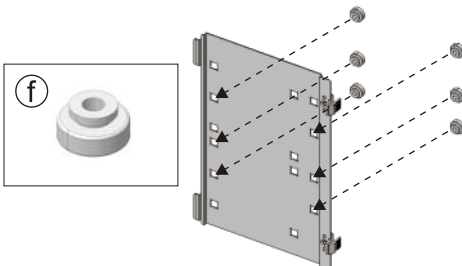

! Pay attention to the installation orientation/
注意安裝方向/
Faites attention à l'orientation d'installation

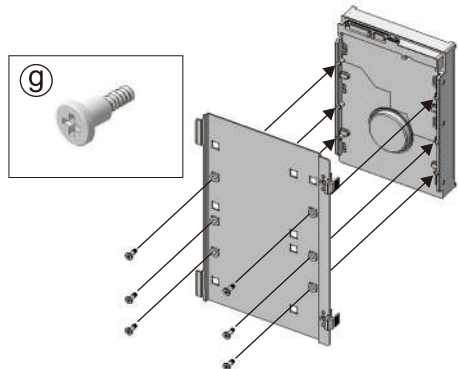

Remove the Side Fan Bracket

卸下側風扇支架 / Retirez le support du ventilateur latéral / Entfernen Sie die seitliche Lüfterhalterung /
Retire el soporte del ventilador lateral / サイドファンブラケットを取り外します

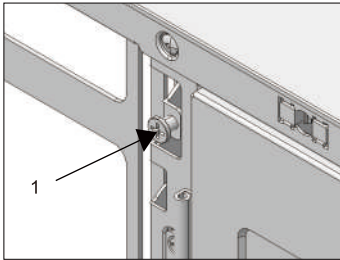

Push/推/Pousser

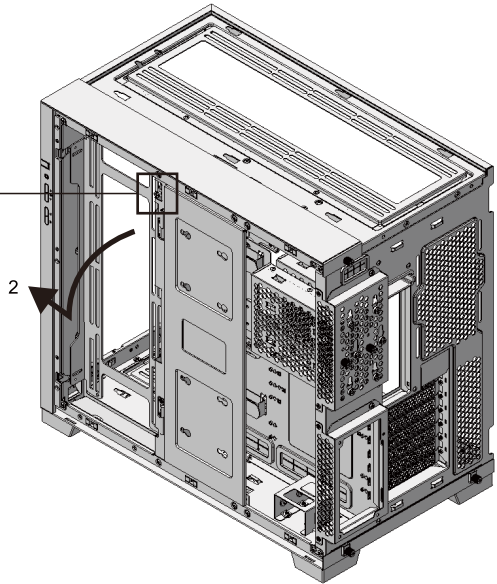

Attention: The fan bracket can be reversed, there are 4 installation style/風扇支架可以雙向反轉安裝，
有四種樣式/Le support du ventilateur peut être inversé, il y a 4 styles d'installation

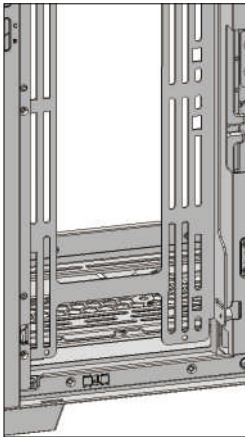

Style 1

Fans install toward the front panel/
樣式1(風扇靠前)/

樣式1(風扇靠前)/

Les ventilateurs s'installent vers le panneau avant

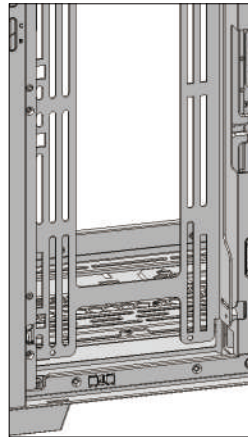

Style 2

Fans install toward the motherboard/
樣式2(風扇靠後)/

樣式2(風扇靠後)/

Les ventilateurs s'installent vers la carte mère

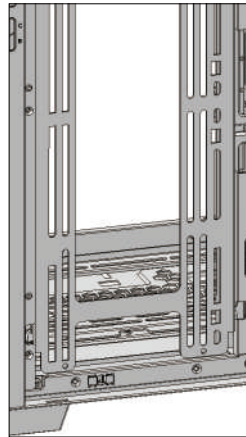

Style 3 (reversed)

Fans install toward the front panel/
樣式3-反轉(風扇靠前)/

樣式3-反轉(風扇靠前)/

Les ventilateurs s'installent vers le panneau avant

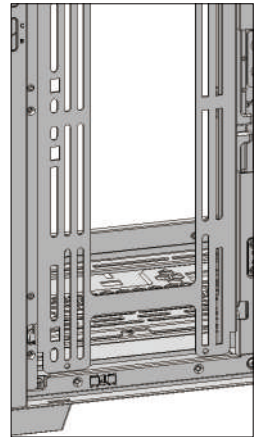

Style 4 (reversed)

Fans install toward the motherboard/
樣式4-反轉(風扇靠後)/

樣式4-反轉(風扇靠後)/

Les ventilateurs s'installent vers la carte mère

Graphic Card Anti-sag Bracket Installation

顯卡支撐架安裝 / Installation du support anti-affaissement de la carte graphique /

Installation der Anti-Sag-Halterung für die Grafikkarte / Instalación del soporte antideslizamiento de la tarjeta gráfica / グラフィックカードのたるみ防止ブラケットの取り付け

Installation 1(For ATX MB)/安裝 1(ATX)/Installation 1(pour ATX MB)

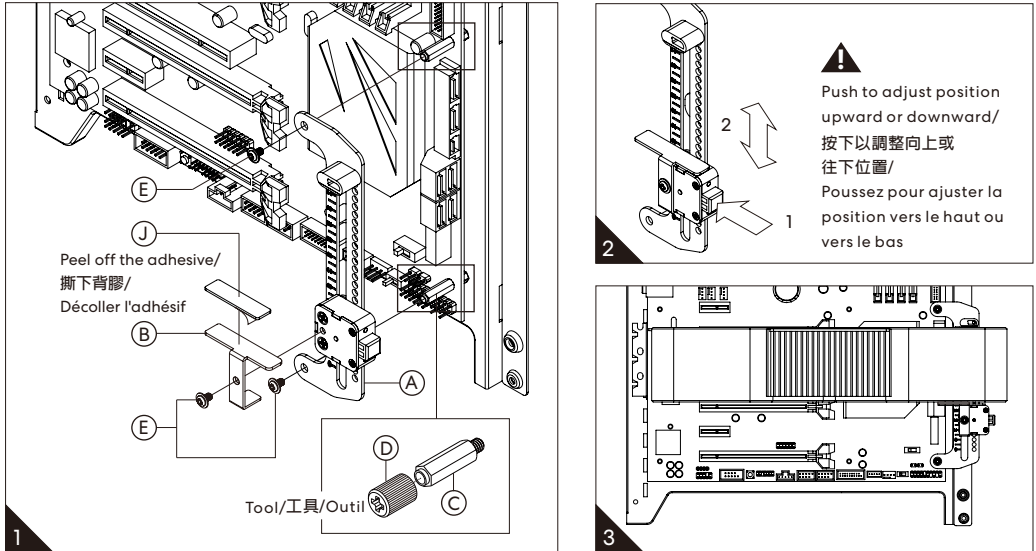

Installation 2 (For E-ATX MB)/安裝 2 (E-ATX MB)/Installation 2 (pour E-ATX MB)

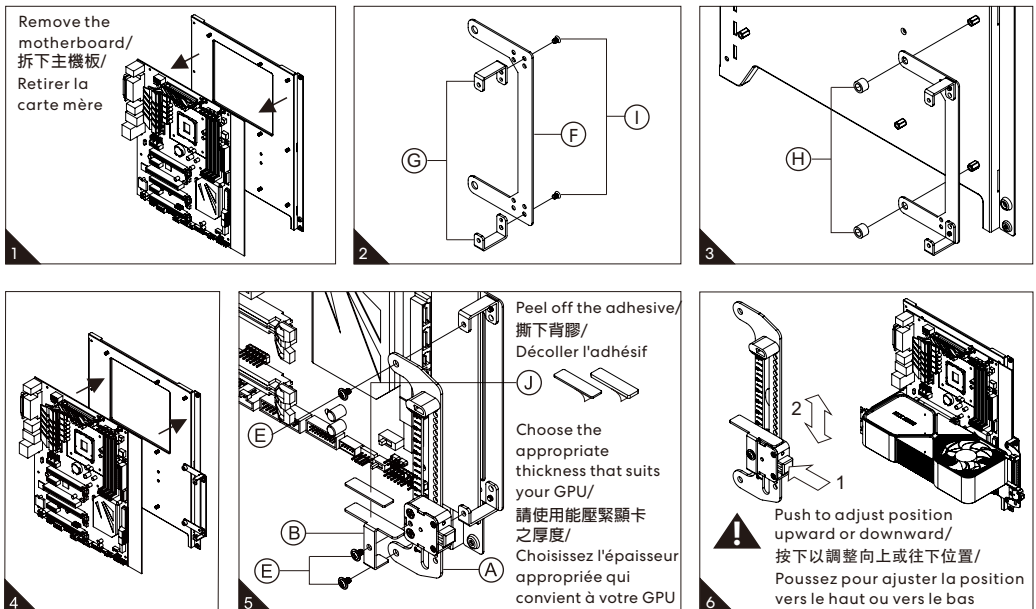

Right Side Panel Installation

右側板安裝 / Installation du panneau latéral droit / Montage der rechten Seitenwand /
Instalación del panel lateral derecho / 右側パネルの取り付け

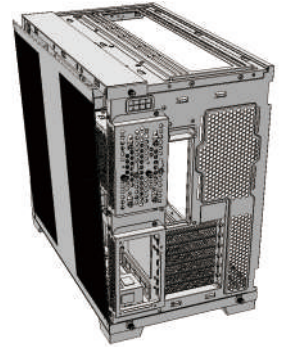
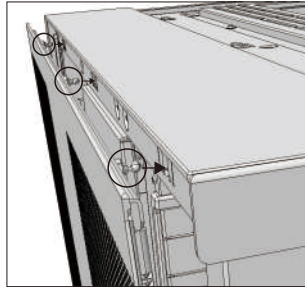
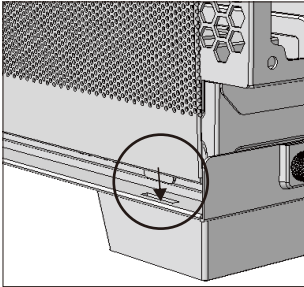

Side & Front Glass Installation

側&前面玻璃安裝 / Pose des vitres latérales et frontales / Seiten- und Frontglasinstallation /
Instalación de vidrio lateral y frontal / 側面と前面のガラスの取り付け

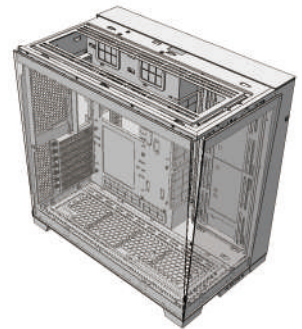
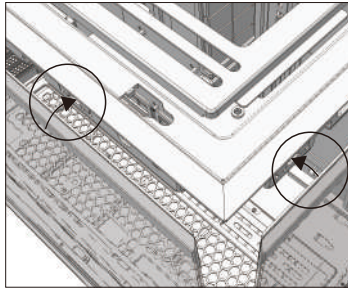
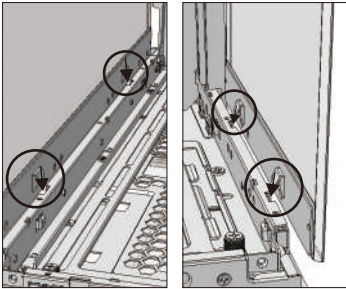

Top cover Installation

上蓋安裝 / Installation du capot supérieur / Montage der oberen Abdeckung / Instalación de la cubierta superior /
トップカバーの取り付け

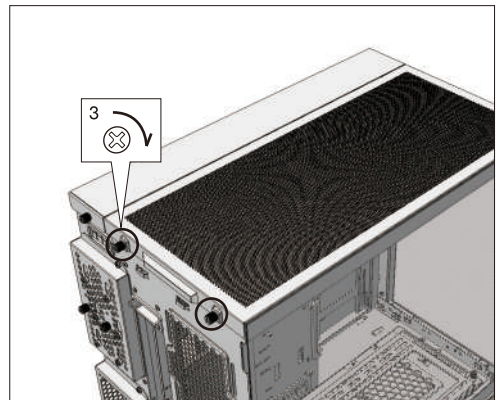
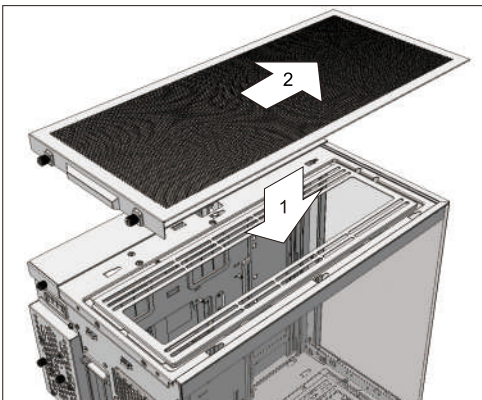

Reverse Mode Installation

Reverse

倒置模式安裝 / Installation en mode inverse / Installation im umgekehrten Modus /
Instalación en modo inverso / リバースモードのインストール

1. Remove the bottom fan bracket/卸除下風扇支架/
Retirez le support du ventilateur inférieur

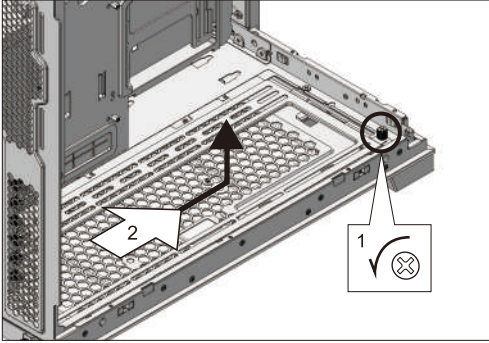

2. Remove the top fan bracket/卸除上風扇支架/
Retirez le support du ventilateur supérieur

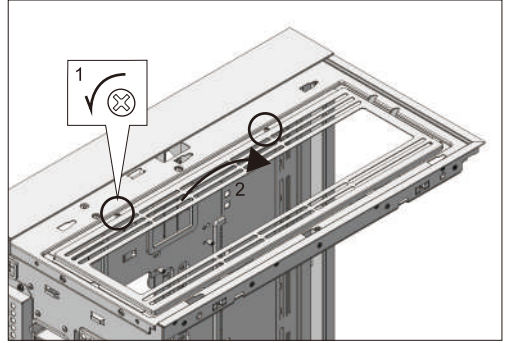

3. Remove the top panel/卸上下板/
Retirez le panneau supérieur

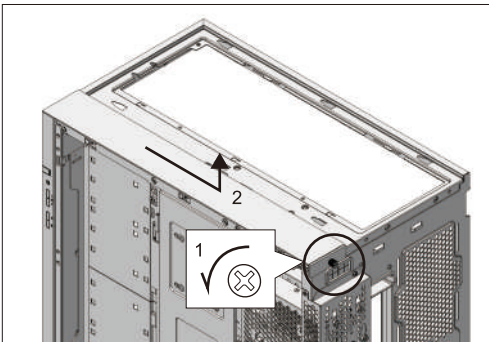

4. Detach the feet frame from the chassis (Remove the I/O module before)/將腳座和機殼分離 (先拔掉I/O線)/
Détachez le cadre des pieds du châssis (retirez le module d'E/S au préalable).

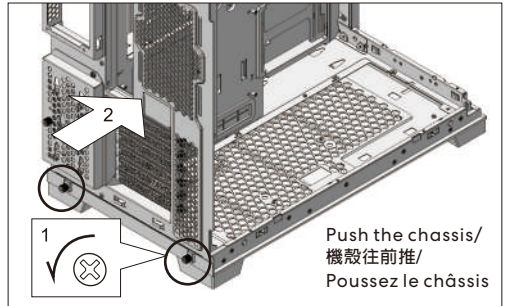

5. Remove the PSU support bracket/
將機殼倒置，拆除電源支撐架/
Retirez le support du bloc d'alimentation

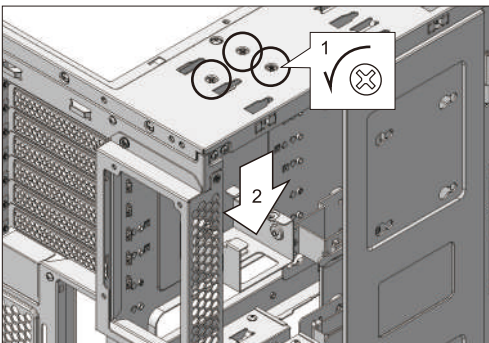

6. Swap the PSU mounting bracket and hard drive bracket positions/互換PSU安裝架與硬碟架位置/
Échangez les positions du support de montage de l'alimentation et du support de disque dur.

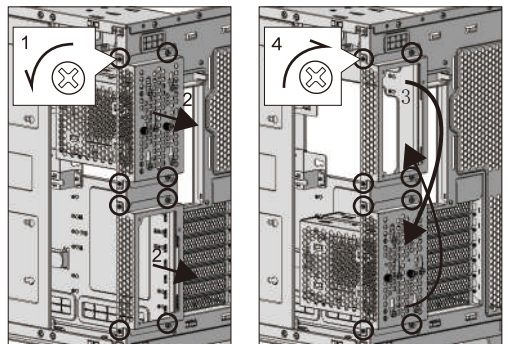

Reverse Mode Installation

Reverse

反向模式安裝 / Installation en mode inverse / Installation im umgekehrten Modus /
Instalación en modo inverso / リバースモードのインストール

7. Install the power supply support bracket/安裝電源
支撐架/Installer le support de l'alimentation

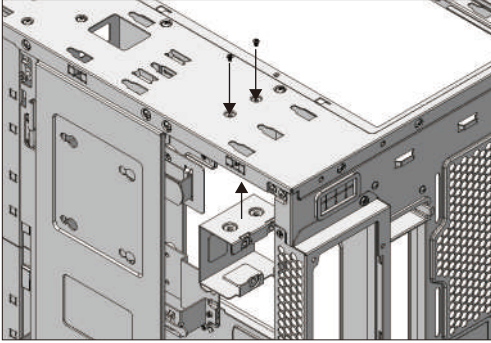

8. Install to the feet frame/鎖上腳座/
Installer sur le cadre des pieds

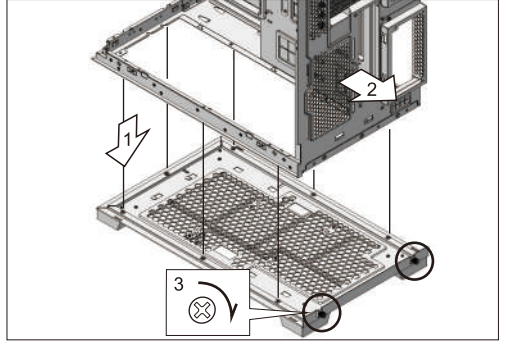

Reverse 2.5" SSD Installation

Reverse

2.5" SSD 安裝 / Installation de 2.5" SSD / 2.5" SSD-Installation
/ Instalación de 2.5" SSD / 2.5" SSD の取り付け

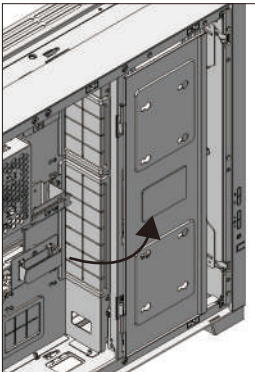

Way 1: Swing 180° to open/
使用方式一：翻轉180度/
Méthode 1: Pivotez à 180°
pour ouvrir

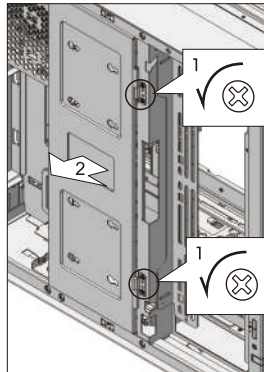

Way 2: Release/
使用方式二：二取下/
Voie 2: Libérer

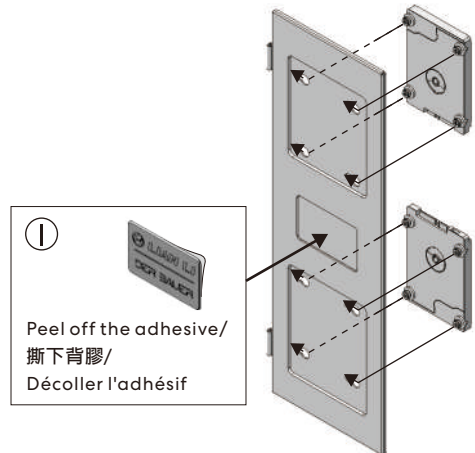
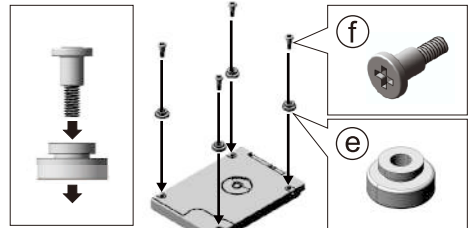

①

Peel off the adhesive/
撕下背膠/
Décoller l'adhésif

Reverse

PSU Installation

電源供應器安裝 /
Installation du plateau du bloc
d'alimentation /
PSU-Einsatz installieren /
Instalación de la fuente de
alimentación /
電源のインストール

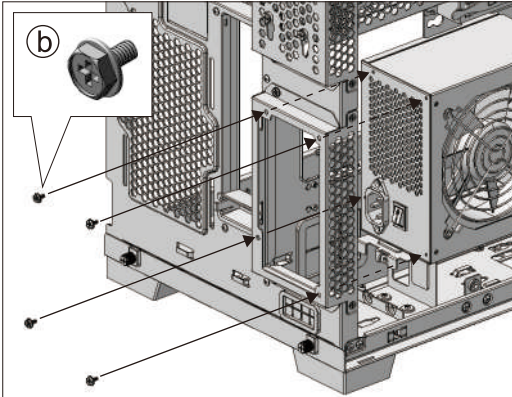

Way 1: Install Directly/使用方式一：直接安裝/
Méthode 1 : Installer directement

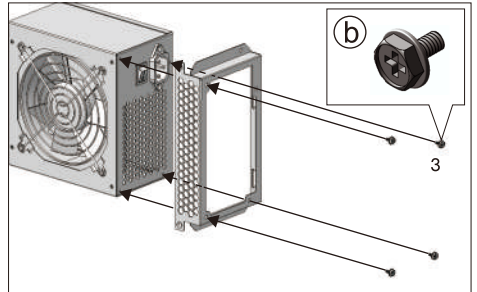
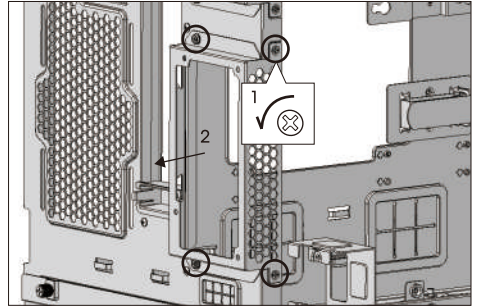

Way 2: Remove the bracket and install/使用方式二：
拆下支架安裝/Voie 2 : Retirez le support et installez

Reverse

2.5" SSD, 3.5" HDD Installation

2.5" SSD, 3.5" HDD 安裝 / Installation de 2.5" SSD, 3.5" HDD / 2.5" SSD, 3.5" HDD-Installation /
Instalación de 2.5" SSD, 3.5" HDD / 2.5" SSD, 3.5" HDD の取り付け

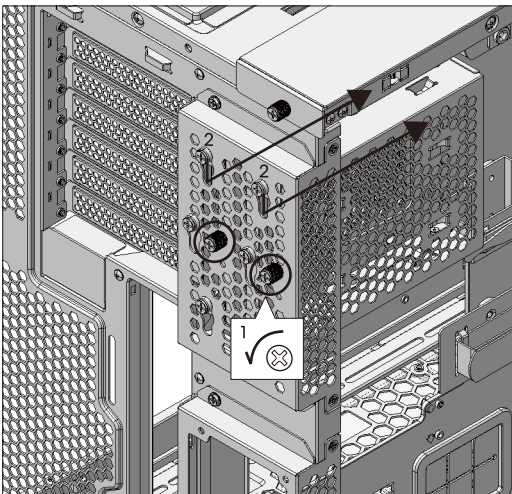

If space is needed, the hard drive cage can be removed/
如有空間需求可將硬碟籠卸除/
Si de l'espace est nécessaire, la cage du disque dur p
être retirée

2.5" SSD Installation/
2.5" SSD 安裝/
Installation d'un SSD 2,5"

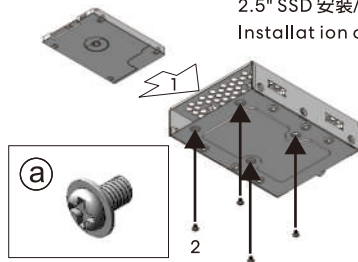

3.5" HDD Installation/
3.5" HDD 安裝/
Installation d'un HDD 3,5"

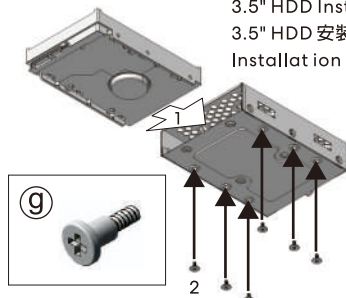

Reverse

I/O Module Location

I/O port 位置變換 / Changement de position du port d'E/S / Positionsänderung des I/O-Ports / Cambio de posición del puerto de E/S / I/Oポートの位置変更

Location 1 / 位置 1 /
Emplacement 1

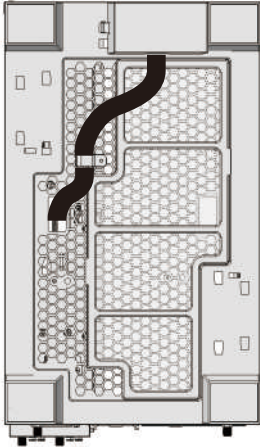

Location 2 / 位置 2 /
Emplacement 2

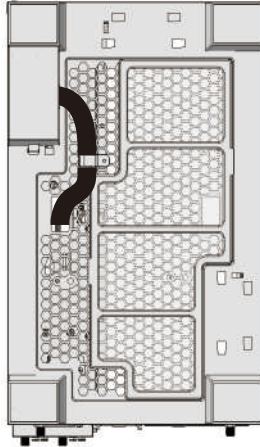

Location 3 / 位置 3 /
Emplacement 3

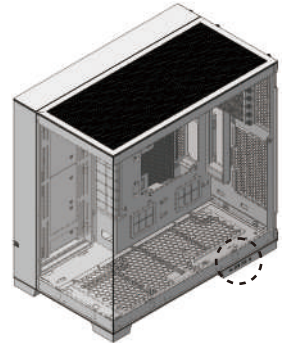
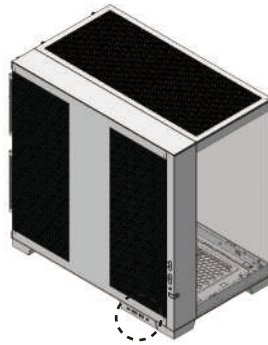
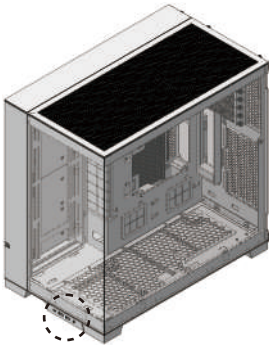
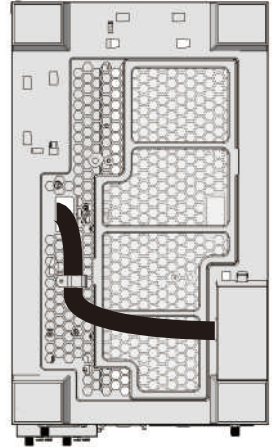

Remove the I/O module/
I/O port 卸除/
Retirer le module I/O

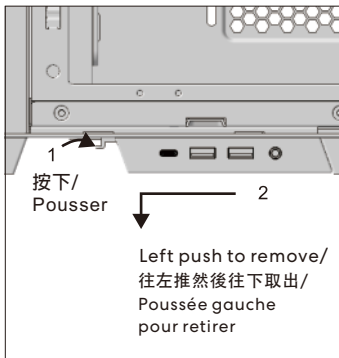

Remove the cable clip/
整線扣卸除/
Retirer le serre-câble

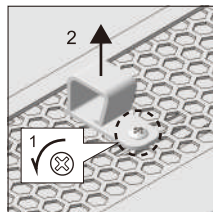

Install the cable clip/
整線扣安裝/
Installez le serre-câble

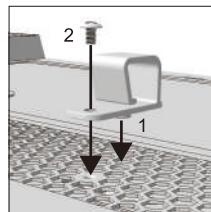

The possible position
for the cable clip/
整線扣變換位置示意/
Les positions possibles
pour le clip de câble

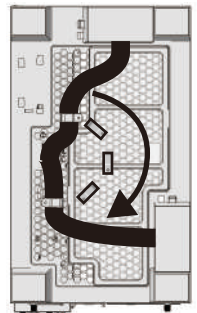

Reverse

Motherboard Installation

主板安裝/Installation de la carte mère / Mainboard-Installation / Instalación de la placa base / マザーボードの取り付け

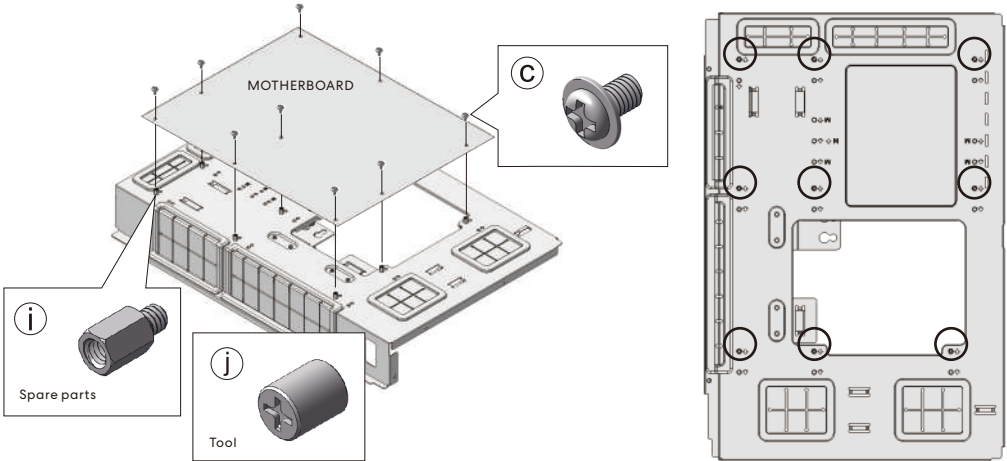

Support of Upper Position (Default Position)

上置模式支援説明(出廠預設)/

Support de Position Supérieure (Position par Défaut)/Oberste Position unterstützen (Standardposition)/

Soporte de Posición Superior (Posición Predeterminada)/上部位置のサポート (デフォルトの位置)

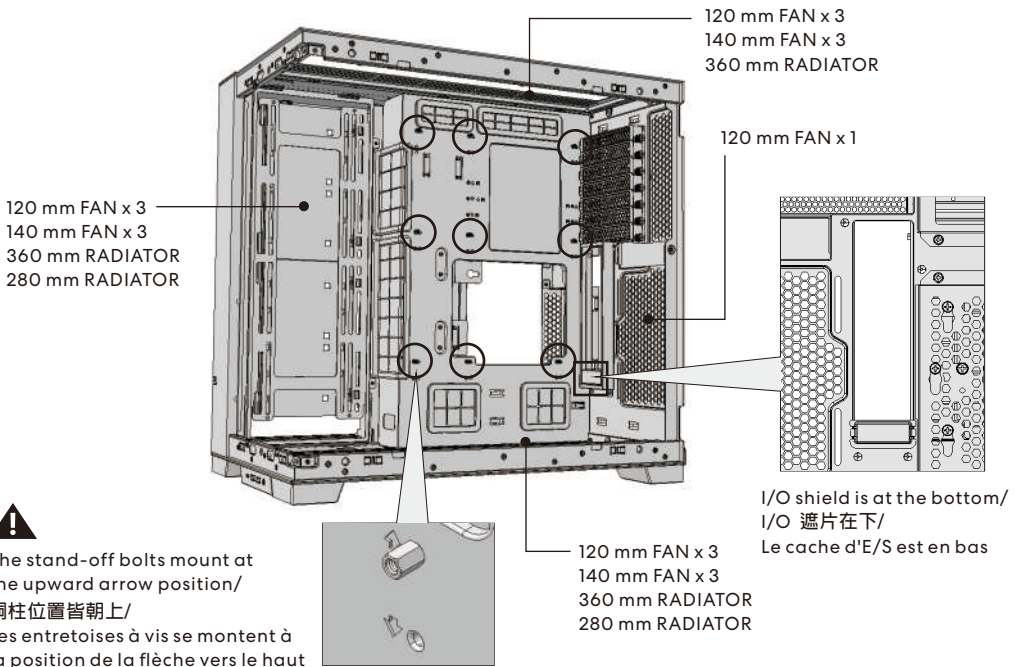

Reverse Switch Motherboard Mounting Position

Reverse

模式變換說明/Changer la Position de Montage de la Carte Mère/Mainboard-Montageposition wechseln/Cambiar la Posición de Montaje de la Placa Base/マザーボード取り付け位置の切り替え

Move the stand-off bolts position/
更換銅柱位置/Déplacer la position des entretoises à vis

Change the position of the I/O shield/
更換I/O遮片位置/Changer la position du cache d'E/S

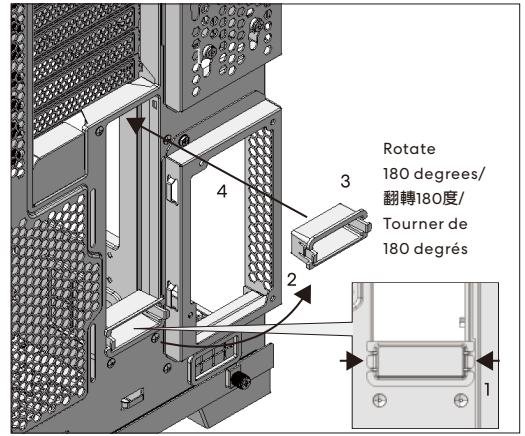
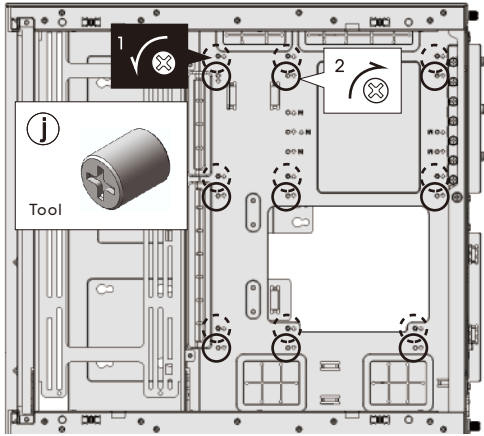

Rotate
180 degrees/
翻轉180度/
Tourner de
180 degrés

Support of Lower Position

下置模式支援說明/Support de Position Inférieure/Unterstützung der unteren Position/
Soporte de Posición Inferior/下部位置のサポート

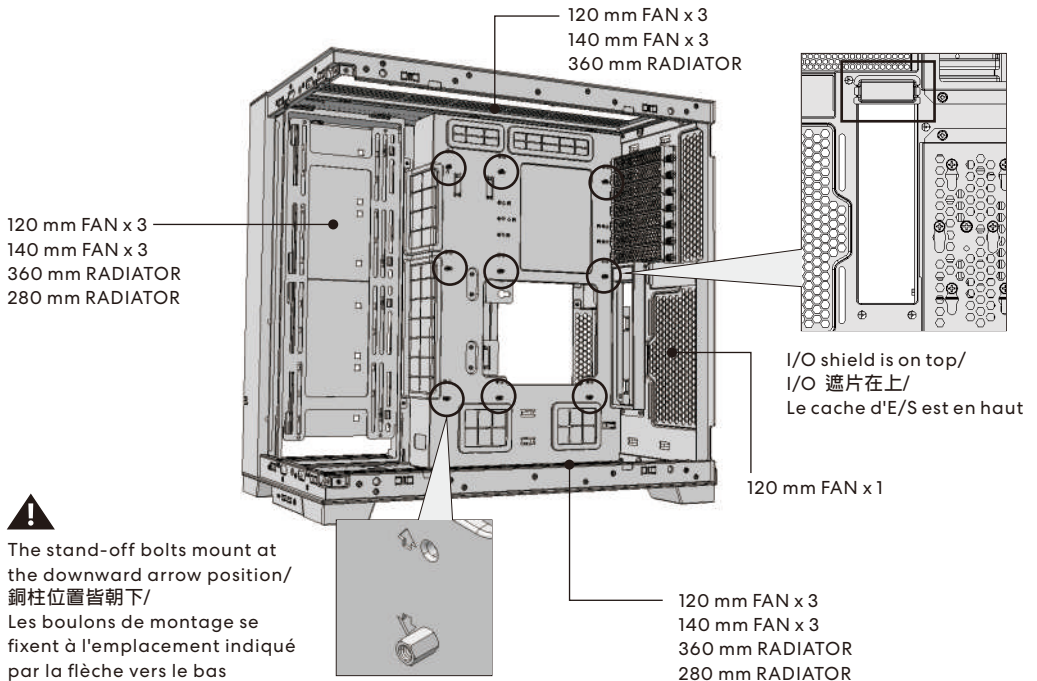

Reverse

Cable management

線材整理/Gestion des câbles/
Kabelmanagement/
Mantenimiento de cable/
ケーブル管理

Cable holder installation

整線扣安裝方式/Installation complète de la boucle du câble/
Instalación der gesamten Kabelschnalle/
Instalación de hebilla de cable completo/
全ラインバックルの取り付け

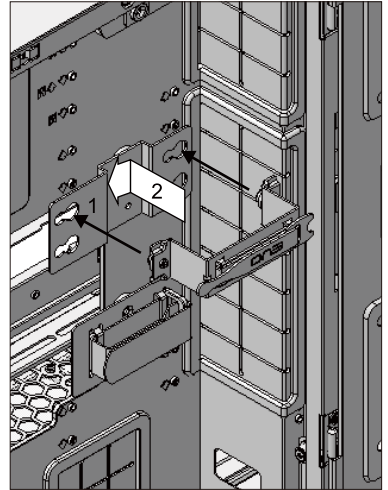
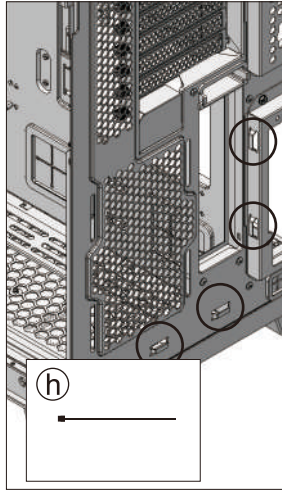
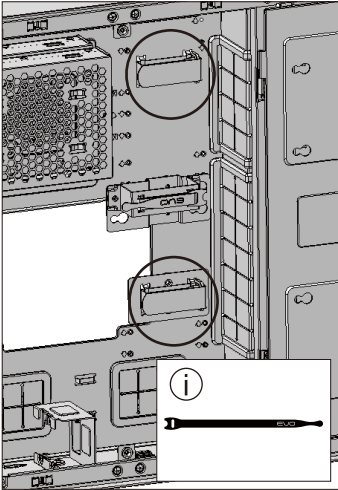

Use of cable holder

整線扣整線說明 / Description complète de la ligne complète de la boucle du câble / Ganze Beschreibung der gesamten Kabelschnalle / Descripción de toda la línea de hebilla de cable completo / バックル全体 ライン全体

Keep the big cables in the cable holders/
先將粗線整在金屬框架內/
Gardez les gros câbles dans les porte-câbles

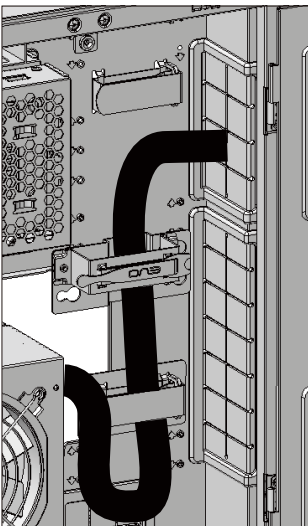

Hold the small cables with the velcro straps/
再將細線使用魔鬼氈整好/
Maintenez les petits câbles avec les bandes velcro

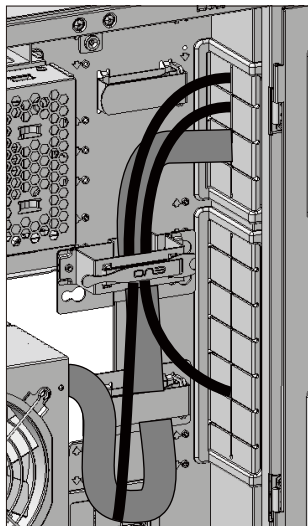

Remove the velcro strap to place a controller/
亦可拆下魔鬼氈作為控制器黏貼處/
Retirez la bande velcro pour placer un contrôleur

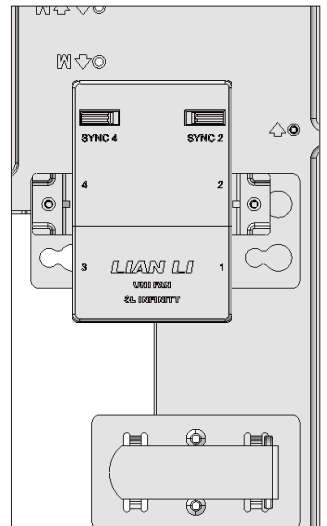

Reverse Install the Top Fan Bracket

安裝上風扇支架 / Installer le support de ventilateur supérieur / Installieren Sie die obere Lüfterhalterung / Instale el soporte del ventilador superior / 上部ファンブラケットを取り付けます

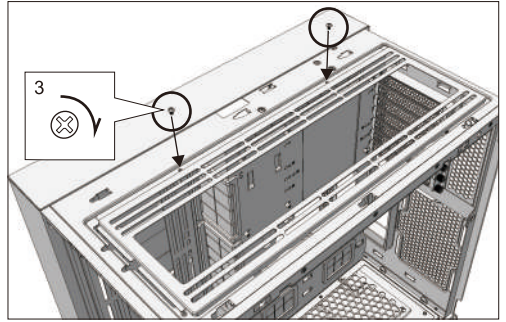
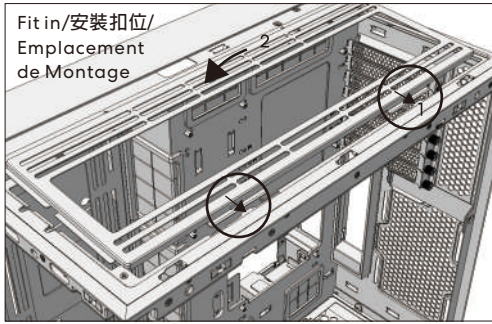

Reverse Bottom fan bracket Installation

安裝下風扇支架/Installer le support de ventilateur inférieur/Installieren Sie die untere Lüfterhalterung/Instale el soporte del ventilador inferior/下部ファンブラケットを取り付けます

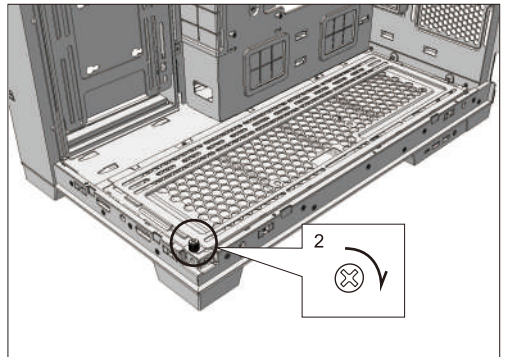
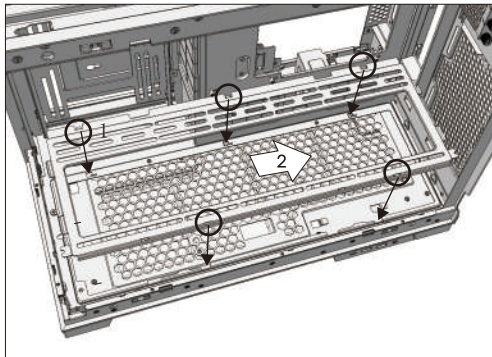

Reverse Dust Filter Installation

灰塵濾網安裝 / Installation de filtre à poussière / Staubfilterinstallation / Instalación del filtro de polvo / ダストフィルターの取り付け

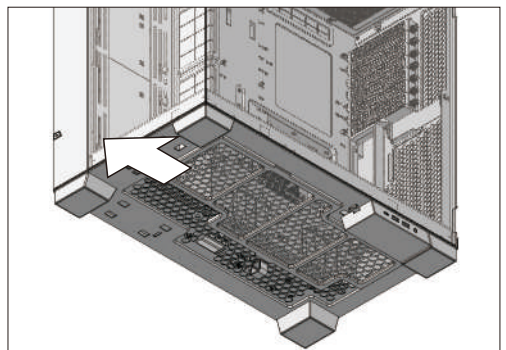
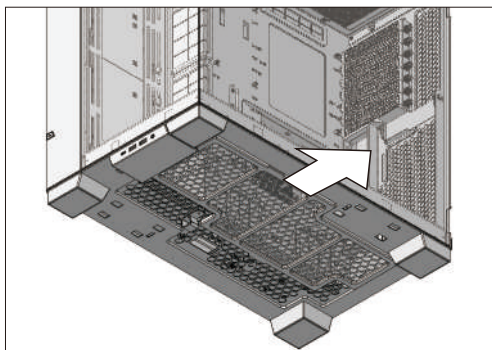

Reverse

Remove Hard Drive Bracket

卸除硬碟安裝架 / Retirer le support de disque dur / Festplattenhalterung entfernen /
Quitar el soporte del disco duro / ハードドライブブラケットを取り外す

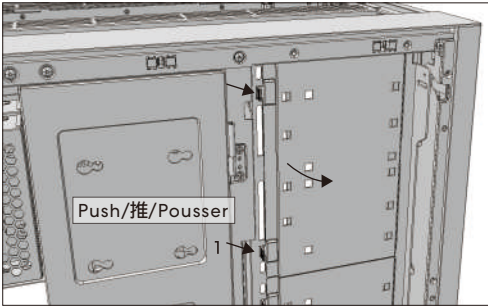

Fit in/安裝扣位/
Emplacement de Montage

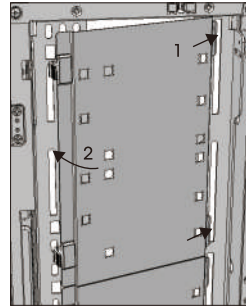

Gap for cable routing/
過線空間/Espace pour le
passage des câbles

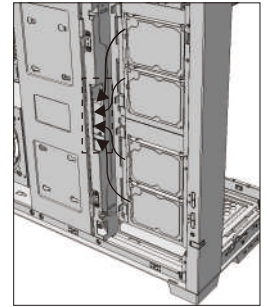

2.5" SSD, 3.5" HDD installation

2.5" SSD, 3.5" HDD 安裝 / Installation de 2.5" SSD, 3.5" HDD / 2.5" SSD, 3.5" HDD-Installation /
Instalación de 2.5" SSD, 3.5" HDD / 2.5" SSD, 3.5" HDD の取り付け

2.5" SSD installation/
2.5" SSD 安裝
Installation d'un SSD 2.5"

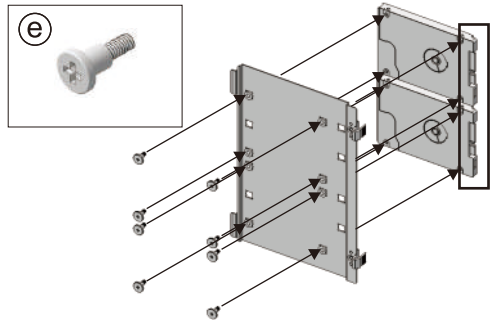
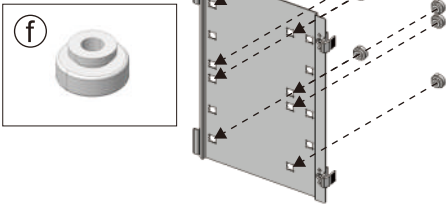

3.5" HDD installation/
3.5" HDD 安裝
Installation d'un HDD 3.5"

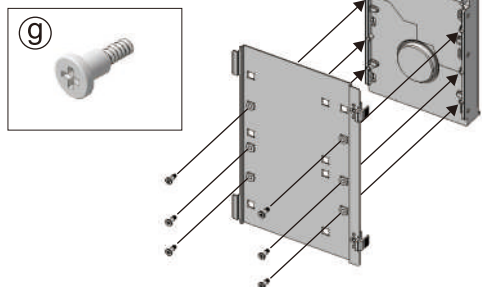
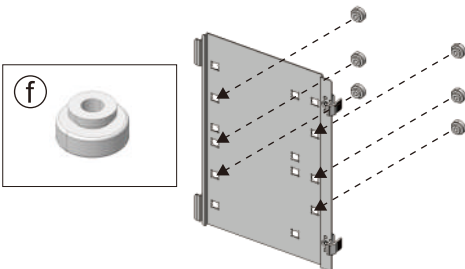

! Pay attention to the installation orientation/
注意安裝方向/
Faites attention à l'orientation d'installation

Reverse

Remove the Side Fan Bracket

卸下側風扇支架/Retirez le support du ventilateur latéral/Entfernen Sie die seitliche Lüfterhalterung/Retire el soporte del ventilador lateral / サイドファンブラケットを取り外します

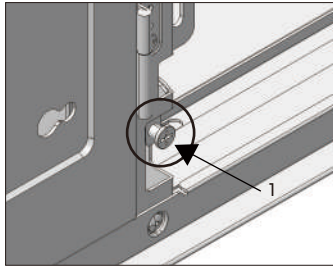

Push/推/Pousser

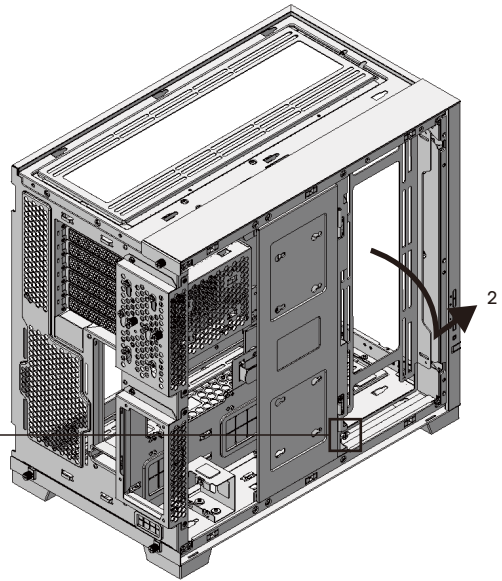

Attention: The fan bracket can be reversed, there are 4 installation style/風扇支架可以雙向反轉安裝，有四種樣式/Le support du ventilateur peut être inversé, il y a 4 styles d'installation

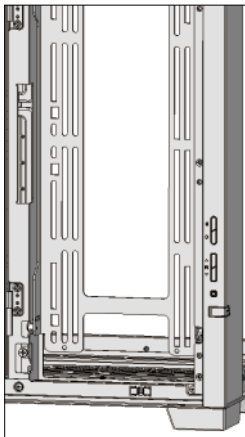

Style 1

Fans install toward the front panel/
樣式1(風扇靠前)/

Les ventilateurs s'installent vers le panneau avant

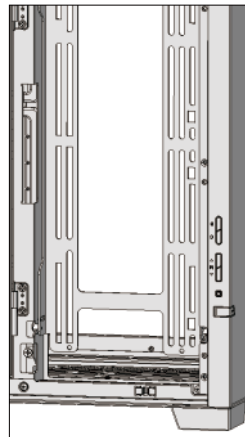

Style 2

Fans install toward the motherboard/
樣式2(風扇靠後)/

Les ventilateurs s'installent vers la carte mère

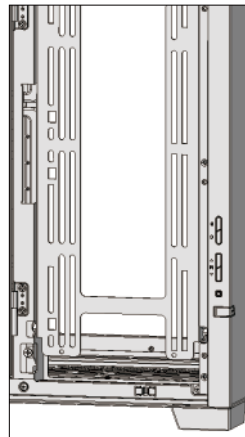

Style 3 (reversed)

Fans install toward the front panel/
樣式3-反轉-(風扇靠前)/

Les ventilateurs s'installent vers le panneau avant

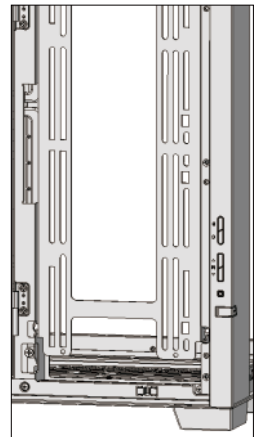

Style 4 (reversed)

Fans install toward the motherboard/
樣式4-反轉-(風扇靠後)/

Les ventilateurs s'installent vers la carte mère

Reverse Graphic Card Anti-sag Bracket Installation

Reverse

顯卡支撐架安裝/Installation du support anti-affaissement de la carte graphique/
Installation der Anti-Sag-Halterung für die Grafikkarte/Instalación del soporte
antideslizamiento de la tarjeta gráfica/グラフィックカードのたるみ防止ブラケットの取り付け

Installation 1(For ATX MB)/安裝 1(ATX)/Installation 1(pour ATX MB)

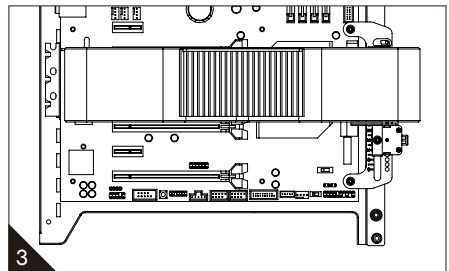
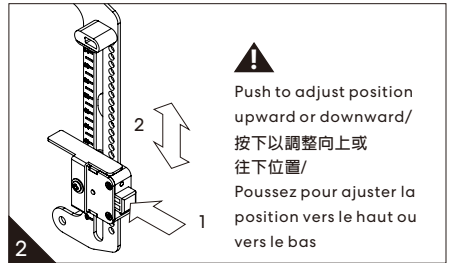
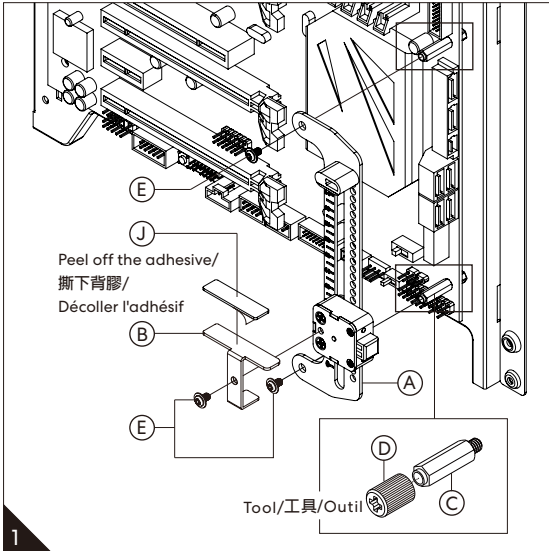

Installation 2 (For E-ATX MB)/安裝 2 (E-ATX MB)/Installation 2 (pour E-ATX MB)

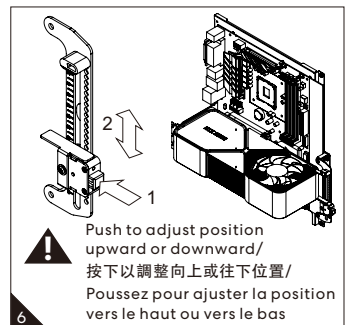
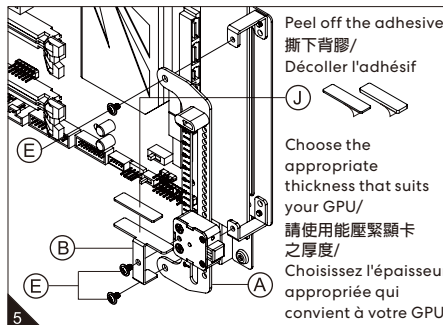
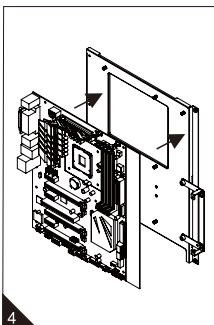
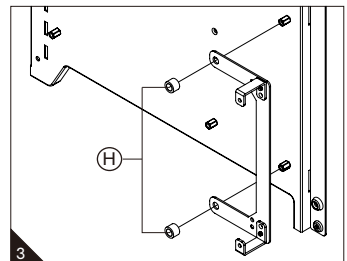
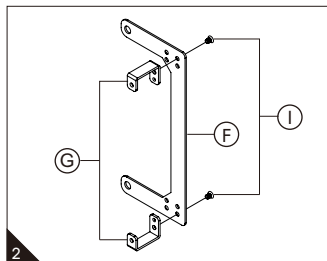
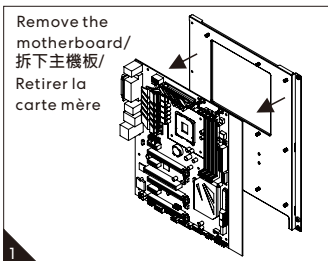

Reverse

Right Side Panel Installation

右側板安裝 / Installation du panneau latéral droit / Montage der rechten Seitenwand /
Instalación del panel lateral derecho / 右側パネルの取り付け

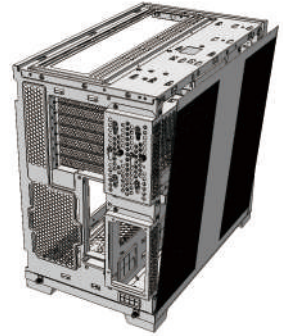
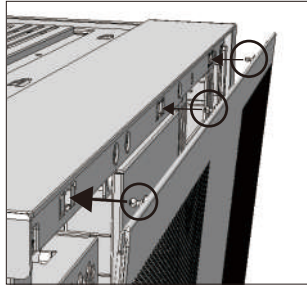
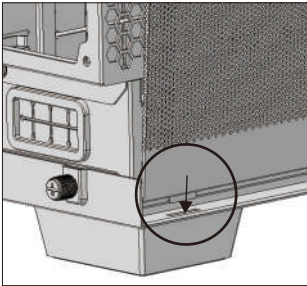

Side & Front Glass Installation

側&前面玻璃安裝/Pose des vitres latérales et frontales / Seiten- und Frontglasinstallation /
Instalación de vidrio lateral y frontal / 側面と前面のガラスの取り付け

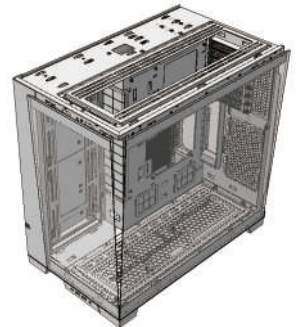
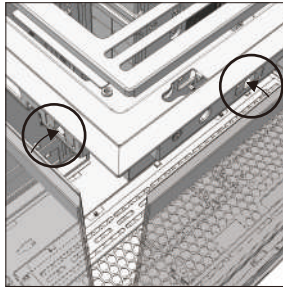
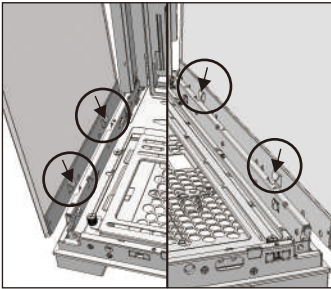

Top cover Installation

上蓋安裝 / Installation du capot supérieur / Montage der oberen Abdeckung / Instalación de la cubierta superior /
トップカバーの取り付け

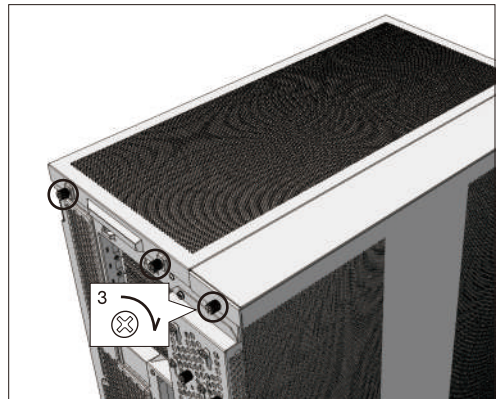
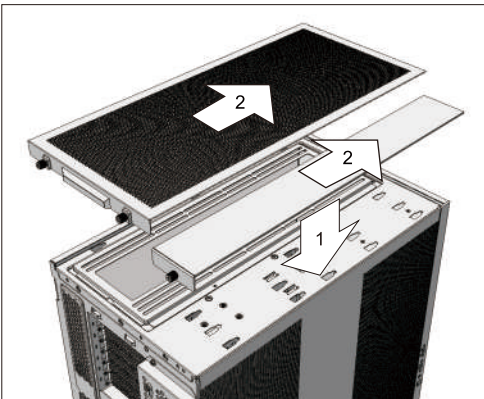

Hardware Clearance

硬體擴充支援 / Liquidation du matériel / Hardware-Freigabe / Liquidación de hardware / ハードウェアクリアランス

CPU height clearance/CPU高度間隙/
Dégagement en hauteur du processeur

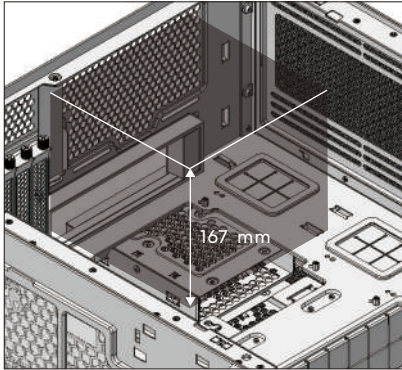

GPU clearance/GPU間隙/Dégagement GPU

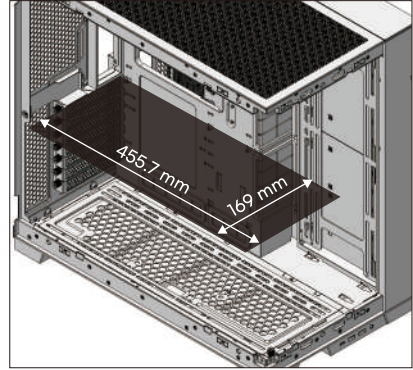

Clearance for lower position/下置模式空間/
Dégagement pour la position inférieure

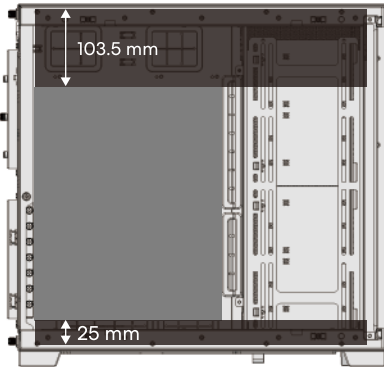

Clearance for upper position/上置模式空間/
Dégagement pour la position supérieure

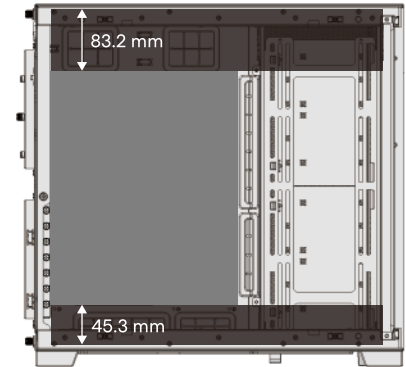

Clearance for side radiator/
側邊散熱器支援尺寸/
Dégagement pour le radiateur latéral

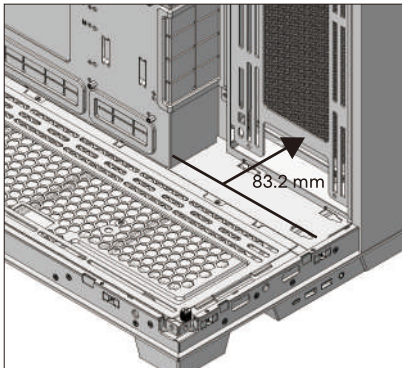

Clearance for side radiator (bracket reverse)/
側邊散熱器支援尺寸(反裝)/Dégagement pour
le radiateur latéral (support inversé)

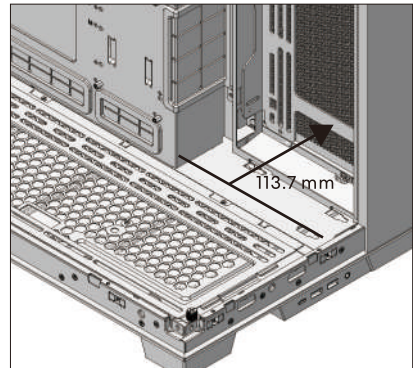

Option Kits

選配件 / Kits d'options / Optionssätze / Kits de opciones / オプションキット

VG4-4-V2X / VG4-4-V2W

Universal
4-Slots Vertical GPU Kit
(with Gen 4 riser)

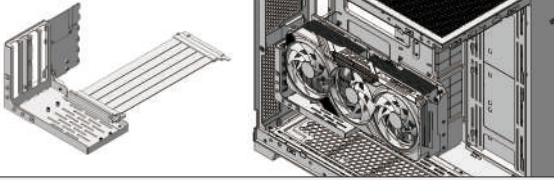

Only Normal Mode can be installed this optional kit/
只有正常模式可以安裝此選配件/
Cet accessoire ne peut être installé qu'en mode normal

O11DERGB-4X / O11DERGB-4W

Front Mesh Kit

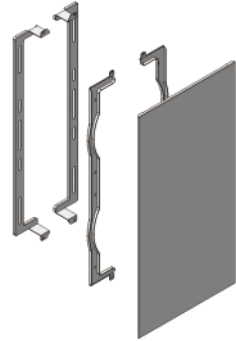

O11DE-9X / O11DE-9W

Upright GPU Bracket for 40 Series GPU

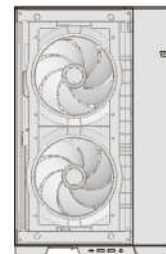
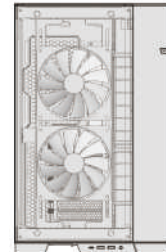
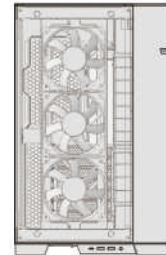
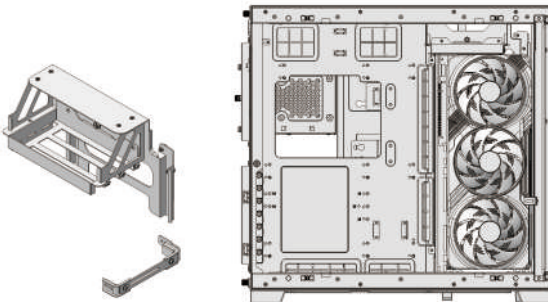

O11DE-3X V2 / O11DE-3W V2

Additional I/O Kit V2

